

A Safe Workplace

A Workplace Safety and Health Manual for your Community

Section: III-C	Rules, Procedures, Practices and Guidelines	Page: 10
Subject:	Safe Work Procedure	Effective Date: April 01-05 Revision Date : December 30, 2005
Ref: G-5	Excavation Shoring	

PPE Required: Steel-toe boots, safety glasses, hearing protection, hard hat, coveralls, gloves

General:

1. Shoring is required on:
 - a) open excavations exceeding 2.4 metres (8 feet), or
 - b) a trench excavation exceeding 1.8 metres (6 feet) where vee-type slopes are not practical.
2. All shoring must be designed by a professional engineer and inspected by the design engineer prior to entering excavations.
3. Where pre-manufactured trench shoring is used, ensure that the shoring system is adequate for the purpose intended.
4. The *Excavation Shoring Procedure* is to be used in conjunction with the *Excavation Procedure* (section III-C, page 7).

Steps:

1. Provide ladder(s) for access/egress in the excavation. Ladders must extend 1 metre (3 feet) above the top of the excavation.
2. When shoring is in progress, the bucket of the excavation machine must be placed in front of the shoring being installed. The bucket will serve as additional protection if a cave-in occurs.

Frozen ground is not considered an alternative to proper shoring

A Safe Workplace

A Workplace Safety and Health Manual for your Community

Section: III-C	Rules, Procedures, Practices and Guidelines	Page: 11
Subject:	Safe Work Procedure	Effective Date: April 01-05 Revision Date : December 30, 2005
Ref: G-5	Excavation Shoring	

3. Install shoring jacks/struts from the top down. Place the first approximately 0.5 metres (18 inches) below the surface (see Shoring Components drawing below).

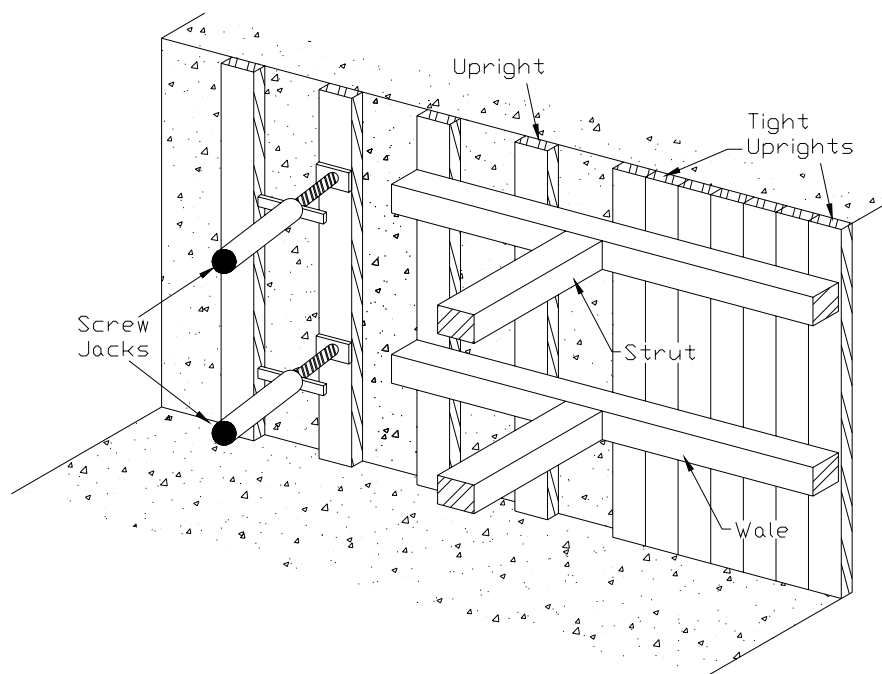

4. Once there is a minimum of two struts/jacks placed on the uprights, the bottom strut/jack can be installed. There must never be less than two struts/jacks used on each set of shoring.
5. Workers entering the trench are to use proper *Confined Space Entry Procedure* (section III-C, page 16).
6. For removal, the process is reversed.

Note additional information can be found on the Department of Labour and Immigration website www.gov.mb.ca/labour/safety/publications in the Guidelines for Trenching and Excavation.