

by S. Lin, D. Jiang¹, E.C. Syme, M.T. Corkery and A.H. Bailes

Lin, S., Jiang, D., Syme, E.C., Corkery, M.T. and Bailes, A.H. 1998: Structural study in the southern Knee Lake area, northwestern Superior Province, Manitoba (part of NTS 53L/15); in Manitoba Energy and Mines, Geological Services, Report of Activities, 1998, p. 96-102.

SUMMARY

The Southern Knee Lake shear zone is a major structure in the Oxford Lake-Knee Lake greenstone belt. The shear zone curves from east-southeast trending in the west to south-southeast-trending in the east. Away from the curving portion of the shear zone, both foliation and lineations are well developed. In the area near the curve, only lineations are well developed. In the east-southeast-trending segment of the shear zone, the foliation is always steep and the stretching lineations have variable orientations, from subhorizontal to down dip. In the south-southeast-trending segment, both the foliation and lineations are steep. In both segments of the shear zone the deformation is dextral transpressional. The east-southeast-trending segment exhibits more zone boundary-normal movement component and less boundary-parallel movement component than the south-southeast-trending segment. Rocks near the curve in the shear zone experienced simultaneous zone boundary-normal and zone-strike-parallel deformation (constrictional deformation). The geometry, kinematics and observed structures can be explained by northward movement of the block to the southwest of the shear zone.

INTRODUCTION

A multidisciplinary study of the Oxford Lake-Knee Lake greenstone belt was initiated in 1997 (Syme et al., 1997) and continued in 1998

(Syme et al., GS-19, this volume). Investigations at Knee Lake form components of Manitoba Energy and Mines' Northern Superior Initiative that has also been linked to the joint federal-provincial Western Superior NATMAP Project. A primary objective of this study is to better understand the volcanic, structural and tectonic evolution of the greenstone belt, its implications for the geological evolution of the Western Superior Province, and the setting of contained mineral deposits.

The structure of southern Knee Lake was studied in detail in the summer of 1998. This area was selected for detailed structural study because results of mapping in 1997 revealed a large scale shear zone with unique geometry and structural associations. Understanding this structure is important for elucidating the geological evolution of the Oxford Lake-Knee Lake greenstone belt and for the evolution of shear zones in general. The study will also help us to understand the structural setting of gold occurrences hosted in the shear zone.

GEOLOGICAL SETTING

The Oxford Lake-Knee Lake greenstone belt is part of the Sachigo subprovince of the Archean Superior Province (Fig. GS-20-1). Supracrustal rocks in the belt have been assigned to two stratigraphic groups, the older Hayes River Group and the younger Oxford Lake Group (Gilbert, 1985 and references therein) (Fig. GS-20-2).

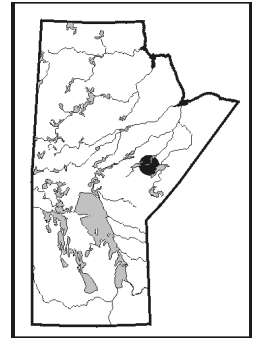

¹Department of Geology, University of New Brunswick, Fredericton, New Brunswick E3B 5A3 Canada

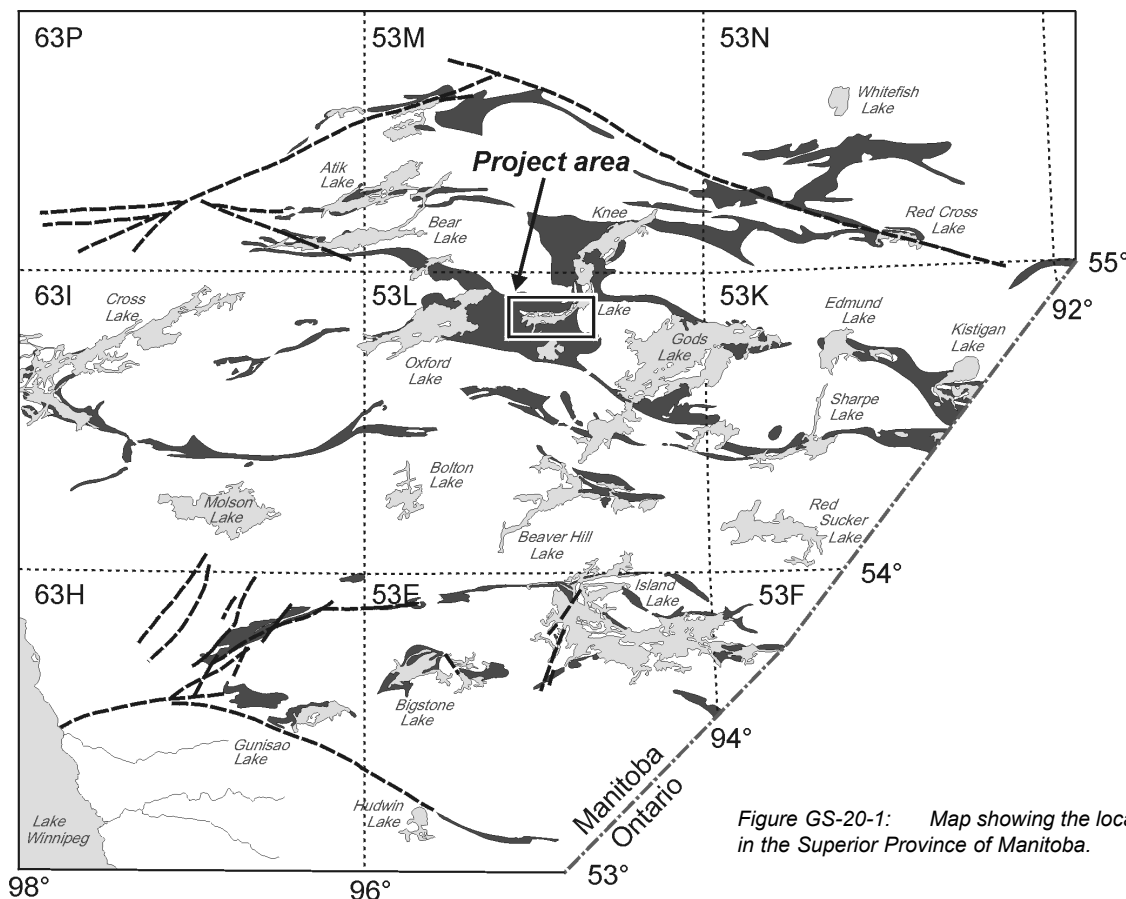
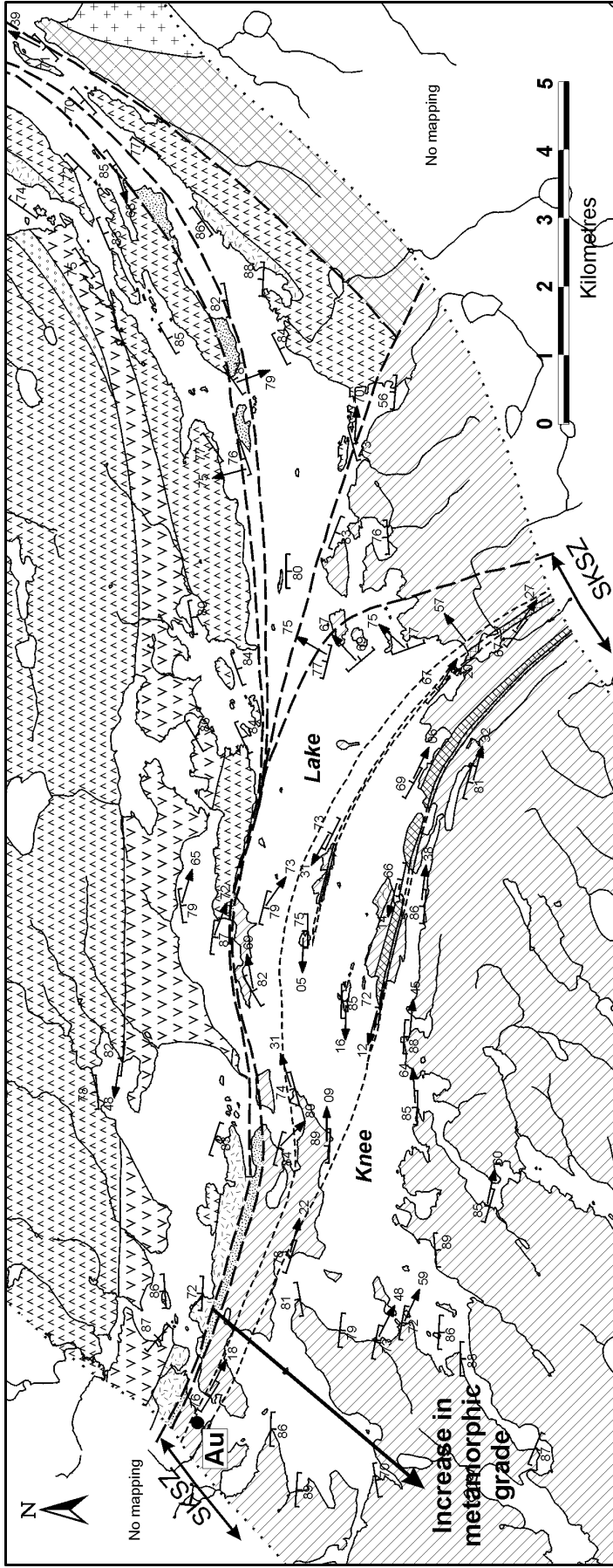

Figure GS-20-1: Map showing the location of the study area in the Superior Province of Manitoba.



HAYES RIVER GROUP

- Mafic volcanic rocks / amphibolite
- Intermediate - felsic volcanic rocks
- Volcanic conglomerate, greywacke

OPISCHIKONA NARROWS SEDIMENTS

- Greywacke, conglomerate

OXFORD LAKE GROUP

- Volcanic rocks/ sedimentary conglomerate, greywacke
- Shoshonite
- Andesite
- Green mafic conglomerate-wacke

INTRUSIVE ROCKS

- Granodiorite
- Gabbro
- Shear zone or fault
- Foliation
- Lineation
- Mineral Occurrence
- SKSZ Southern Kneee Lake shear zone

Figure GS-20-2: Simplified geological map of the southern Kneee Lake greenstone belt. SKSZ: Southern Kneee Lake shear zone. Note that the lineations plunge shallowly near the centre of the shear zone (approximately between the two long, thin dashed lines) and progressively steepen towards the margins on both sides.

The Hayes River Group (ca. 2830 Ma at Knee Lake, D. Davis, cited in Syme et al., 1997) is composed mainly of pillowed basalt and related gabbro, with minor intermediate to felsic volcanic rocks and volcanogenic sedimentary rocks. A well-established stratigraphy in the central Knee Lake consists of a number of lithological units (Syme et al., GS-19, this volume), but only part of this stratigraphy is developed in southern Knee Lake.

The Oxford Lake Group (ca. 2706 Ma at Oxford Lake, D. Davis, cited in Syme et al., 1997) lies unconformably on the Hayes River Group. It consists of polymictic conglomerate, cross-bedded sandstone, volcanoclastic rocks, greywacke and minor andesite and shoshonite lavas.

At central Knee Lake, the Hayes River Group is unconformably overlain by the Opischnikona Narrows sediments comprising greywacke and conglomerate (Syme et al., 1997; GS-19, this volume). These sediments can be traced more or less continuously into southern Knee Lake (Fig. GS-20-2). The relationship between the Opischnikona Narrows sediments and the Oxford Lake Group is unknown. At southern Knee Lake, they are exposed together, but the contact is sheared. Syme et al. (GS-19, this volume) suggest that they are stratigraphically equivalent and part of the same sedimentary sequence.

In general, rocks at Knee Lake are variably metamorphosed. Metamorphic grade at southern Knee Lake increases from greenschist facies in the north to amphibolite facies in the south (Fig. GS-20-2).

STRUCTURE

Rocks of the Hayes River Group are typically weakly to moderately deformed with well-preserved primary features. Strong deformation is concentrated in narrow zones (shear zones) along some lithological contacts.



Figure GS-20-3: Strongly deformed conglomerate of the Oxford Lake group in the southern Knee Lake shear zone.

Oxford Lake Group rocks are generally strongly deformed in southern Knee Lake; the deformation is most pronounced in the southern Knee Lake shear zone (Figs. GS-20-2 and 3), which is the main structure in the area and the focus of this study. The shear zone strikes east-southeasterly in the western part of southern Knee Lake and curves to south-southeast trending towards the east (Fig. GS-20-2). The structures and kinematics of these two segments of the shear zone are different and are described separately below.

The east-southeast-trending segment

In the east-southeast-trending segment of the southern Knee Lake shear zone, both foliation and lineations are well developed. The foliation is defined by transposed bedding, mineral alignment and flattened clasts in fragmental rocks. It always dips steeply (Fig. GS-20-4). The lineations are defined by the long axis of elongated clasts and preferred orientation of elongate minerals (such as amphibole). Importantly, the lineations have variable orientations (Figs. GS-20-2 and 4), from subhorizontal to down dip. Near the centre of the shear zone, lineations are subhorizontal (Figs. GS-20-2 and 5). Towards the margins of the shear zone, on both sides, the lineations progressively steepen (Figs. GS-20-2 and 6). Estimate of finite strain, based on the shape of the deformed clasts in fragmental rocks, shows that in this segment of the shear zone the strain ellipsoid is oblate ($0 < K < 1$) and the deformation is of flattening type. Shear sense indicators are observed at several localities and are best developed on subhorizontal surfaces, irrespective of the orientation of the lineations. They all indicate dextral shearing (Fig. GS-20-7). This structural association indicates that this segment of the shear zone is a dextral transpressional zone (Lin et al., 1998); a transpressional shear zone is a shear zone that contains both a zone-boundary-parallel velocity component and a boundary-normal component.

The south-southeast-trending segment

Only a small portion of the south-southeast-trending segment of the shear zone is exposed on Knee Lake, near the curve of the shear zone. The shear zone was traversed about 10 km south of Knee Lake to examine the structures associated with this segment of the shear zone in an area away from the curve. We found that these rocks are very strongly deformed, with well-developed foliation and lineations. The foliation dips steeply and the lineations plunge steeply. As in the east-southeast-trending segment of the shear zone, shear sense indicators are best developed on horizontal surfaces, consistently indicating dextral

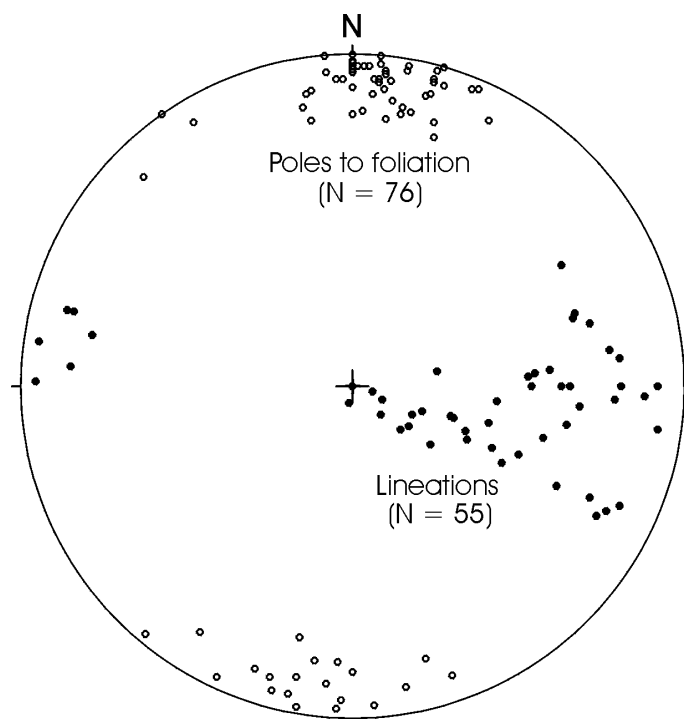

Figure GS-20-4: Equal-area lower-hemisphere projection of foliation and lineations from southern Knee Lake shear zone.



Figure GS-20-5: Subhorizontal lineations in deformed conglomerate near the centre of the east-southeast-trending segment of the southern Knee Lake shear zone.



Figure GS-20-6: Steep lineations in deformed conglomerate near the margin of the east-southeast-trending segment of the southern Knee Lake shear zone.

shearing (Fig. GS-20-8). Although the outcrop south of Knee Lake is very poor, shear sense indicators are in fact more commonly observed than in the much better-exposed east-southeast-trending segment of the shear zone at southern Knee Lake. We interpret this observation to indicate that there is more simple shear component in the south-southeast trending part of the shear zone than in the east-southeast trending portion on southern Knee Lake.

The curve between the east-southeast-trending and south-southeast-trending segments

In the area where the shear zone curves from east-southeast trending to south-southeast trending (Fig. GS-20-2), the rocks are strongly deformed and the strain geometry is unique. Lineations are well developed and always plunge steeply. However, the foliation is only weakly developed. The strain ellipsoid is clearly prolate ($K \gg 1$), the deformation is of constrictional type, and the rocks can thus be termed L-tectonites (i.e., very strong lineations and very weak foliation) (Fig. GS-20-9). Sheath folds are observed with fold hinges parallel to the lineation (Fig. GS-20-10). This structural association indicates that rocks in this part of the shear zone experienced both zone boundary-normal and zone strike-parallel compression (e.g., Fossen and Tikoff, 1998).

Interpretation

An interpretation of the geometry and kinematics of the southern Knee Lake shear zone is summarized in Fig. GS-20-11. We suggest that the block southwest of the shear zone moved approximately northwards and is bounded by the southern Knee Lake shear zone. The movement of this block was at a small angle to the shear zone boundary at the south-southeast-trending segment. Here the deformation is dextral transpressional, but a simple shear component is dominant. This explains why shear sense indicators (or evidence for non-coaxial deformation) are more commonly observed in this segment of the shear zone. Along the east-southeast-trending segment of the shear zone, the movement of the block was at high angle to the shear zone boundary. The deformation here is also dextral transpressional, but the boundary-normal compression is much more significant. The boundary-parallel shearing is dextral oblique (oblique transpression) and contained a south-over-north thrust component. This oblique transpression (with triclinic symmetry) explains why the lineations vary continuously from subhorizontal to down dip (Lin et al., 1998). The thrust component explains the observed southward increase in metamorphic grade. Under these boundary conditions, the rocks in the curved part of the shear zone experienced both zone boundary-normal and zone-strike-parallel compression (constrictional deformation).

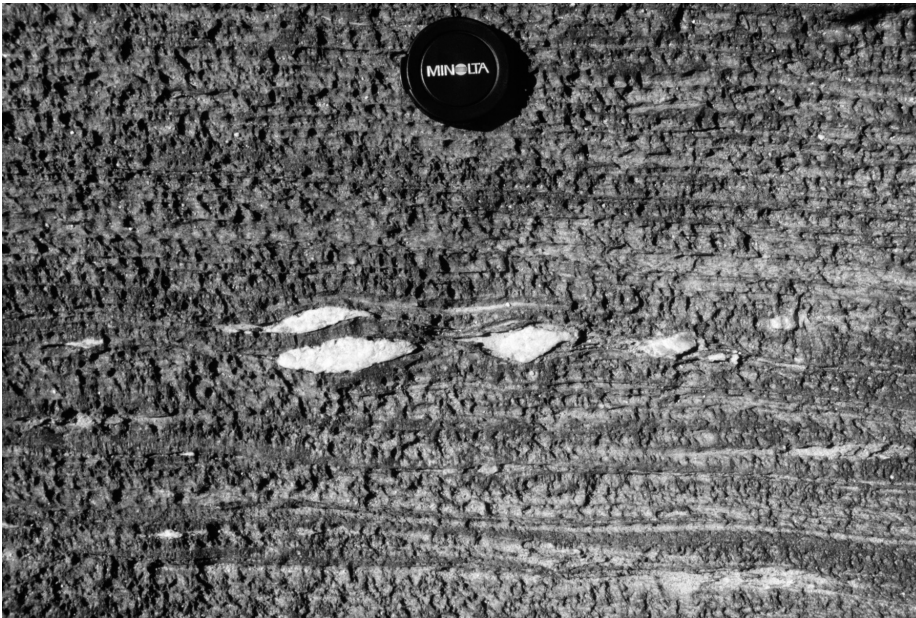

Figure GS-20-7: Shear bands and back-rotated boudins in mafic metavolcanic rocks indicating dextral shearing along the east-southeast-trending segment of the southern Knee Lake shear zone. Note that the photographed surface is subhorizontal and the stretching lineations at the outcrop plunge steeply. This structural association is common in transpressional shear zones.

Figure GS-20-8: Shear bands and back-rotated boudins in deformed conglomerate indicating dextral shearing along the south-southeast-trending segment of the southern Knee Lake shear zone. Note that the photographed surface is subhorizontal and the stretching lineations in this part of the shear zone plunge steeply. This structural association is common in transpressional shear zones.

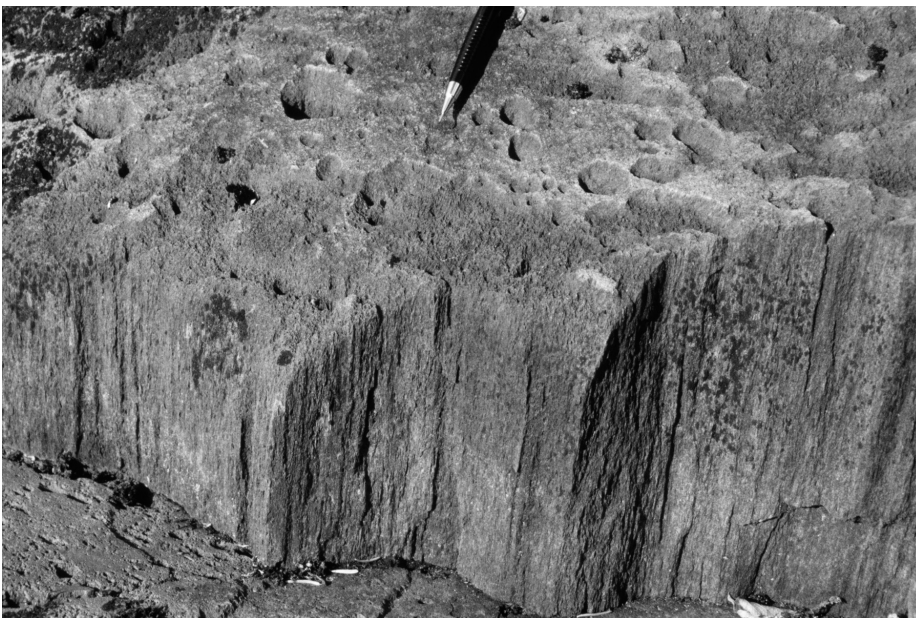
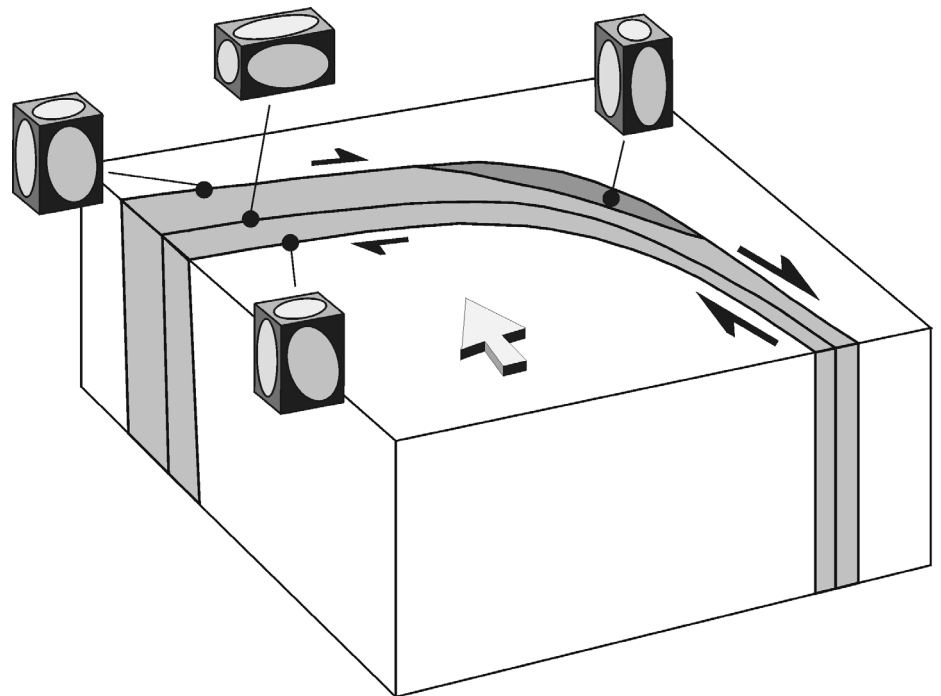

Figure GS-20-9: L-tectonite (very strong lineation and very weak foliation) developed in the area near where the shear zone curves from east-southeast trending to south-southeast trending.



Figure GS-20-10: Sheath fold, below the coin, developed in the area near where the shear zone curves from east-southeast-trending to south-southeast trending.

Figure GS-20-11: Schematic diagram summarizing the main structural features of the southern Knee Lake shear zone and our proposed interpretation.



IMPLICATIONS FOR GOLD EXPLORATION

Gold mineralization has been documented at southern Knee Lake, spatially associated with the southern Knee Lake shear zone (Fig. GS-20-2), a zone of transpressional shear. Transpressional shear zones are the hosts of many gold deposits. For example, most gold deposits in the Abitibi greenstone belt are spatially associated with the

Kirkland Lake-Larder Lake-Cadillac break, interpreted to be a transpressional shear zone (Robert, 1989; Robin and Cruden, 1994). Mineralization in such shear zones commonly occurs at the releasing or restraining bends. The east-southeast-trending segment of the southern Knee Lake shear zone is potentially a restraining bend. Elucidation of the complete geometry and kinematics of the shear zone will require additional mapping in the surrounding areas, e.g., in the Oxford Lake area.

REFERENCES

- Fossen, H. and Tikoff, B.
1998: Extended models of transpression and transtension, and application to tectonic settings; **in** Holdsworth, R.E., Strachan, R.A., and Dewey, J.F. (eds), *Continental Transpressional and Transtensional Tectonics*, Geological Society, London, Special Publications, No. 135, p. 15-33.
- Gilbert, H.P.
1985: *Geology of the Knee Lake - Gods Lake area*; Manitoba Energy and Mines, Geological Services, Geological Report GR83-1B, 76 p.
- Lin, S., Jiang, D. and Williams, P.F.
1998: Transpression or transtension zones of triclinic symmetry: natural example and theoretical modeling; **in** Holdsworth, R.E., Strachan, R.A., and Dewey, J.F. (eds), *Continental Transpressional and Transtensional Tectonics*, Geological Society, London, Special Publications, No. 135, p. 41-57.
- Robert, F.
1989: Internal structure of the Cadillac tectonic zone southeast of Val d'Or, Abitibi greenstone belt, Quebec; *Canadian Journal of Earth Sciences*, v. 26, p. 2661-2675.
- Robin, P.-Y. F. and Cruden, A. R.
1994: Strain and vorticity patterns in ideally ductile transpressional zones. *Journal of Structural Geology*; v. 16, p. 447-466.
- Syme, E.C., Corkery, M.T., Bailes, A.H., Lin, S., Cameron, H.D.M. and Prouse, D.
1997: Geological investigations in the Knee Lake area, north-western Superior Province; **in** Manitoba Energy and Mines, Report of Activities 1997, p. 37-46.