



July 30, 2019

Cordella Friesen, M.P.A.  
Acting Director and Assistant Deputy Minister  
Manitoba Sustainable Development  
Environmental Stewardship Division  
Environmental Approvals Branch  
1007 Century Street  
Winnipeg, MB R3H 0W4

Client File No.: 1071.10  
Our File Nos.: S-1146, S-972, EMS  
020-17-08-11-00  
020-17-08-11-00

Dear Madam,

**RE: Requirement to Submit a Notice of Alteration - City of Winnipeg North End Water Pollution Control Centre (NEWPCC)**

Attached is a 'Notice of Alteration Request' (NOA) in response to Manitoba Sustainable Development's January 23, 2019 letter. This letter required the City of Winnipeg Water and Waste Department (City) to submit a request by July 31, 2019. The NOA is a request for an extension to December 31, 2021 so that an interim licence compliance plan can be developed and submitted.

Due to the size, complexity, and costs of the work, the North End Sewage Treatment Plant (NEWPCC) Upgrade has been divided into three projects which will be constructed and commissioned in order of process criticality:

- The NEWPCC Upgrade: Power Supply and Headworks Facilities – approved by Council and in progress
- NEWPCC Upgrade: Biosolids Facilities
- NEWPCC Upgrade: Nutrient Removal Facilities

The City has reviewed opportunities to expedite construction and/or construct the projects in parallel. The projects may run concurrently subject to available funding. The City is currently exploring opportunities for provincial and federal funding to support the work. However, a final date for compliance cannot be committed to at this time because the Biosolids Facilities and the Nutrient Removal Facilities are subject to available funding and Council approval.

The City has also reviewed alternative options for interim phosphorous compliance, some using chemicals. After a review of possible alternatives, it was determined that compliance to 1 mg/L phosphorous is not be achievable due to the size and process constraints of the City's existing sludge treatment system. Some chemical phosphorous removal, as described by the Lake Winnipeg Foundation, may be possible but would not achieve the 1 mg/L effluent requirement.

In order to determine how much phosphorous can be removed from the NEWPCC using chemicals, the City will conduct further process reviews and testing. Due to the limitations of the existing digestion system, specifically digester capacity, chemical interim phosphorous removal at NEWPCC cannot be implemented until the SEWPCC Nutrient Removal facility has been commissioned and is operating reliably with its nutrient-rich sludge treated in the NEWPCC sludge treatment system.

**DIRECTOR'S OFFICE**

1199 Pacific Avenue, Winnipeg, Manitoba R3E 3S8

**BUREAU DE LA DIRECTRICE**

1199, avenue Pacific, Winnipeg (Manitoba) R3E 3S8

T. | Tél. : 204-986-7550

F. | Fax : 204-986-3745

winnipeg.ca

The City will continue its efforts to protect Lake Winnipeg by exploring partial chemical phosphorous removal at NEWPCC, finish upgrading the SEWPCC for nutrient removal, and by supporting external environmental efforts (e.g. Lake Winnipeg Research Consortium, Save Our Seine, and the Red River Basin Commission Netley-Libeu Marsh Rehabilitation).

An extension to December 31, 2021 will provide: time for an interim compliance plan to be developed; time for funding opportunities to be explored; the SEWPCC Nutrient Removal Facility to be integrated into the City's sludge treatment system (project schedule dependant); and for studies and testing for partial chemical trimming at NEWPCC.

Should you have any questions on this NOA, please contact Geoff Patton at 204-986-4477 or by email at [gpatton@winnipeg.ca](mailto:gpatton@winnipeg.ca).

Sincerely,

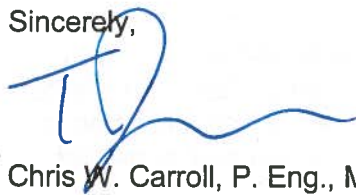
A handwritten signature in blue ink, appearing to read "Chris W. Carroll".

for Chris W. Carroll, P. Eng., MBA  
Manager of Wastewater Services Division

A handwritten signature in blue ink, appearing to read "Geoff Patton".

Geoff Patton, P. Eng.  
Manager of Engineering Services Division

Attachment:

- Notice of Alteration Application Form
- City of Winnipeg Request for a 'Notice of Alteration' for the North End Sewage Treatment Plant Environment Act Licence No. 2684RRR

MP/dr

- c:
- Scott Davies, Manitoba Sustainable Development (email)
  - Yvonne Hawryliuk, MSc, Manitoba Sustainable Development (email)
  - M.L. Geer, CPA, CA, Water and Waste Department (email)
  - G.K. Patton, P.Eng., Water and Waste Department (email)
  - R. Grosselle, Water and Waste Department (email)
  - D.E. Griffin, P.Eng., Water and Waste Department (email)
  - J. Veilleux, P.Eng., Water and Waste Department (email)

**DIRECTOR'S OFFICE**

1199 Pacific Avenue, Winnipeg, Manitoba R3E 3S8

**BUREAU DE LA DIRECTRICE**

1199, avenue Pacific, Winnipeg (Manitoba) R3E 3S8

T. | Tél. : 204-986-7550

F. | Fax : 204-986-3745

[winnipeg.ca](http://winnipeg.ca)

Notice of Alteration Form

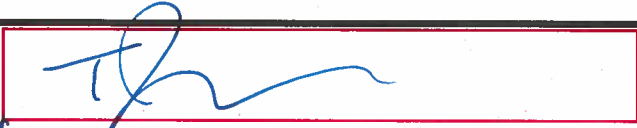

Client File No. : 1071.00	Environment Act Licence No. : 2684RRR
Legal name of the Licencee: City of Winnipeg	
Name of the development: North End Water Pollution Control Centre	
Category and Type of development per Classes of Development Regulation: Waste Treatment and Storage                      Wastewater treatment plants	
Licencee Contact Person: Chris Carroll, P.Eng Mailing address of the Licencee: 1199 Pacific City: Winnipeg                      Province: Manitoba                      Postal Code: R3E 1G5 Phone Number: (204) 986-7435    Fax:                      Email: ccarroll@winnipeg.ca	
Name of proponent contact person for purposes of the environmental assessment (e.g. consultant): Geoff Patton	
Phone: (204) 986-4477 Fax:	Mailing address: 1199 Pacific Winnipeg, MB, R3E 1G5
Email address: gpatton@winnipeg.ca	
Short Description of Alteration (max 90 characters): Request extension for nutrient removal compliance	
Alteration fee attached:    Yes: <input checked="" type="checkbox"/> No: <input type="checkbox"/>	
If No, please explain:	
Date: <b>July 30, 2019</b>	Signature:  Printed name: Chris Carroll
<p>A complete Notice of Alteration (NoA) consists of the following components:</p> <ul style="list-style-type: none"> <li><input checked="" type="checkbox"/> Cover letter</li> <li><input checked="" type="checkbox"/> Notice of Alteration Form</li> <li><input checked="" type="checkbox"/> 2 hard copies and 1 electronic copy of the NoA detailed report (see "<a href="#">Information Bulletin - Alteration to Developments with Environment Act Licences</a>")</li> <li><input checked="" type="checkbox"/> \$500 Application fee, if applicable (Cheque, payable to the Minister of Finance)</li> </ul>	
<p><b>Submit the complete NoA to:</b></p> <p>Director Environmental Approvals Branch Manitoba Sustainable Development 1007 Century Street Winnipeg, Manitoba R3H 0W4</p> <p><b>For more information:</b></p> <p>Phone: (204) 945-8321 Fax: (204) 945-5229 <a href="http://www.gov.mb.ca/sd/eal">http://www.gov.mb.ca/sd/eal</a></p>	
<p><b>Note: Per Section 14(3) of the Environment Act, Major Notices of Alteration must be filed through submission of an Environment Act Proposal Form (see "Information Bulletin – Environment Act Proposal Report Guidelines")</b></p>	



City of Winnipeg Request for a 'Notice of Alteration' for  
the North End Sewage Treatment Plant Environment  
Act Licence No. 2684RRR  
July 31, 2019

---



Prepared by: The City of Winnipeg Water and Waste Dept.  
Engineering Services

---

## Table of Contents and Figures

### Table of Contents

Table of Contents and Figures .....	2
Executive Summary.....	3
Introduction .....	5
Background and History.....	5
Progress to Date in Nutrient Removal and Reuse .....	7
Review of Alternatives to Expedite Construction for NEWPCC .....	10
Review of Interim Alternatives for Phosphorous Removal.....	10
Next Steps .....	13
Conclusion.....	14
Appendix 1 Memo: Temporary P Removal by AECOM, 2019.....	15
Appendix 2 Future Activities to Achieve 1 mg/L phosphorous compliance .....	16

## Executive Summary

Manitoba Sustainable Development has requested that the City of Winnipeg submit a 'Notice of Alteration' request for the North End Sewage Treatment Plant (NEWPCC) Environment Act Licence No. 2684RRR. The Licence currently requires that the following effluent criteria be met by the end of 2019:

- A total phosphorous concentration in the effluent less than 1 mg/L on a rolling average
- Total nitrogen concentration in the effluent less than 15 mg/L on a rolling average
- Ammonia removal, specified monthly as a daily never-to-exceed limit

The NEWPCC, however, will not be able to meet these effluent criteria by the end of 2019 and this report serves as a request for a 'Notice of Alteration' for a two year extension to December 31, 2021 so that a plan can be developed for future compliance.

The City of Winnipeg has made steady progress in reducing nutrients to Lake Winnipeg over the past 15 years. In 2008 the NEWPCC was partially upgraded for nutrient removal; the West End Sewage Treatment Plant (WEWPCC) nutrient removal project was finished in that same year. This represents an investment of \$67.2M. Currently the South End Sewage Treatment Plant (SEWPCC) is under construction for biological nutrient removal. This represents an additional investment of \$335.6M for a total investment of \$402.8M. The SEWPCC Upgrade is currently scheduled to be completed by the end of 2021 and once online will result in a total City reduction in phosphorous and nitrogen of approximately 30-35% and 20-25% respectively, compared to pre-2008 levels.

The City has also implemented nutrient recovery and reuse through the biosolids disposal program. Since 2015 the City has steadily increased beneficial reuse of biosolids through composting, land application to farmland, and soil manufacturing for landfill reclamation. In 2018 37-38% of biosolids and their nutrients were reused and this level is expected to increase as these programs are optimized and/or expanded.

As part of the 'Notice of Alteration' request the City was asked to look at alternatives to expedite NEWPCC construction or conduct activities in parallel to implement biological phosphorous removal. The City had initially planned the NEWPCC Upgrade Project as a single project which would have resulted in parallel construction activities. It was considered to be the most expeditious way to comply with the NEWPCC Licence. Unfortunately, due to the size and complexity of the projects it was determined that a single entity could not complete the project. Funding and cost control for a single project was also a concern. The multiple projects can run concurrently if funding is available and each project has incremental benefits for the NEWPCC.

The current plan is to construct the NEWPCC Upgrade as three projects in order of process criticality, as funds become available. The City cannot commit to a specific date for 1 mg/L phosphorous compliance until all projects for the NEWPCC Upgrade have been approved by Council. If funding constraints are alleviated, some projects could be started as its predecessor is being designed and/or constructed. The order of projects is as follows:

1. Power Supply and Headworks, as already approved by City Council on February 28, 2019
2. Biosolids Facilities, start and completion date to be determined by funding agreement
3. Nutrient Removal Facilities, start and completion date to be determined by funding agreement

To date Council has approved the first project, the Power Supply and Headworks project. This project was chosen to be done first because of process criticality. The Nutrient Removal Facilities project cannot come online before the Biosolids Facilities because of the detrimental impacts of nutrient rich sludge. The Biosolids Facilities cannot come online until there is improved grit and screening, which will be done as part of the Power Supply and Headworks project. The three projects may run concurrently but would be subject to available funding.

There has been recent media attention on temporary, interim alternatives to biological phosphorous removal. As part of the 'Notice of Alteration' request, the City explored this and seven other possible interim phosphorous removal options for the NEWPCC. After a review of capacities and process risks it was determined that there are no interim options that will be able to treat phosphorous to an effluent level of 1 mg/L. After the SEWPCC is upgraded, there may be an opportunity for some interim phosphorous reduction at NEWPCC but this will depend on how the existing sludge treatment system (also known as the 'digestion system') reacts to the SEWPCC's nutrient rich sludge.

Moving forward the City will continue in its efforts of nutrient reduction. The SEWPCC Upgrade project is in active construction and the NEWPCC Power Supply and Headworks is in the construction and procurement phase. For the remaining projects, the Biosolids and the Biological Nutrient Projects, the City is currently investigating funding options from other levels of government to complete the work. The City will also continue to conduct research into more cost effective alternatives to traditional biological phosphorous removal.

## Introduction

The North End Sewage Treatment Plant (NEWPCC) is the largest wastewater treatment plant in Winnipeg. It is licensed by Manitoba Sustainable Development (MSD) and currently has a requirement to remove and recycle/recover nutrients (nitrogen, phosphorous, and ammonia) by end of 2019. The NEWPCC plant, however, will not be able to meet these requirements by the end of 2019. In January 2019 MSD requested that the City of Winnipeg Water and Waste Department (City) submit a 'Notice-of-Alteration' request. The following is a request for a two year extension to the compliance date to develop a new plan for compliance.

## Background and History

In August 2003 the Clean Environment Commission (CEC) issued a public hearing report on the City's wastewater infrastructure, entitled "Better Treatment, Taking Action to Improve Water Quality." The report recommended that the City of Winnipeg initiate a program to improve its treated wastewater quality by implementing nitrogen and phosphorous removal at its three sewage treatment plants. It also recommended that these changes should be "directly assisted by the Province of Manitoba in efforts to secure financial support under existing and future infrastructure programs for upgrades to its wastewater collection and treatment systems."<sup>1</sup>

In response to the CEC recommendations the City initiated a program to reduce wastewater nutrients. In 2008 the City's largest sewage treatment plant, the North End Sewage Treatment Plant (NEWPCC) began to partially remove nitrogen, phosphorous, and ammonia. The City's smallest plant, the West End Sewage Treatment Plant (WEWPCC), was upgraded to full biological nutrient removal and came into operation in the same year. The WEWPCC regularly meets the effluent limit of 1 mg/L total phosphorous and is often discharging at levels below 1 mg/L.

Following the 2008 upgrades the City initiated planning for major capital upgrades to its remaining treatment plants, the South End Sewage Treatment Plant (SEWPCC) and the NEWPCC. Various options for nutrient removal were studied, including chemical and biological phosphorous removal. At the same time, Manitoba Conservation (currently known as Manitoba Sustainable Development) requested the CEC investigate nutrient reduction and ammonia treatment at the City of Winnipeg's wastewater treatment facilities. This led the CEC to issue a report in March 2009<sup>2</sup> recommending that the "City of Winnipeg should use nutrient removal processes, such as biological nutrient removal, that increase resource recovery and reduce the City's environmental footprint to the greatest extent possible." The CEC followed up this report again in January 2011 with a "Supplement to An Investigation into Nutrient

---

<sup>1</sup> Better Treatment 'Taking Action to Improve Water Quality'  
[http://www.cecmanitoba.ca/resource/Reports/Commissioned-Reports-2003-2004-Better\\_Treatment\\_Taking\\_Action\\_Improve\\_Water\\_Quality.pdf](http://www.cecmanitoba.ca/resource/Reports/Commissioned-Reports-2003-2004-Better_Treatment_Taking_Action_Improve_Water_Quality.pdf)

<sup>2</sup> Manitoba Clean Environment Commission An investigation into nutrient reduction and ammonia treatment at the City of Winnipeg's wastewater treatment facilities  
[http://www.cecmanitoba.ca/resource/Reports/Hearings-Wastewater-Final\\_Report.pdf](http://www.cecmanitoba.ca/resource/Reports/Hearings-Wastewater-Final_Report.pdf)



Reduction and Ammonia Treatment”<sup>3</sup> which reaffirmed the importance of biological phosphorous removal and phosphorous recovery. It also recommended ammonia and nitrogen removal.

Following this report the Water Protection Act was revised in June 2011<sup>4</sup> to state the following for the NEWPCC:

- “Nutrient removal must be achieved primarily by biological methods through application of the best available technologies”
- “The use of chemical methods to remove nutrients must be minimized”
- “Nutrients that are removed must be recovered and recycled to the maximum extent possible through application of the best available technologies”
- “Bio-solids and wastewater sludge remaining after the treatment process must be reused”.

In response the City altered its plans for the SEWPCC to include a biological nutrient removal treatment process; previous plans had been to use chemical-phosphorous removal. The switch to biological nutrient removal was to maintain consistent processes to reduce training, equipment, and asset management costs. A biological nutrient removal process would also allow for future beneficial reuse of phosphorous once a phosphorous recovery system is incorporated into the future sludge treatment system. A consultant was hired and the SEWPCC Upgrade project was initiated. The project is currently under construction, with a biological nutrient removal plant currently scheduled to come online by the end of 2021, at a capital cost estimate of \$335.6M.

Following the Water Protection Act changes, the City also developed a NEWPCC Master Plan with an emphasis on biological nutrient removal and submitted this to Manitoba Conservation (currently known as Manitoba Sustainable Development). The plan was conditionally approved pending further details and Manitoba Sustainable Development specified new effluent criteria for the NEWPCC. A Biosolids Master Plan was also required demonstrating how the City would beneficially reuse biosolids and nutrients. A revised NEWPCC Master Plan was submitted in April 2014 to convert the NEWPCC to biological nutrient removal. Manitoba Sustainable Development approved the plan and required that the NEWPCC construction be complete by December 31, 2019.

In September 2014 the City submitted a Biosolids Master Plan which had two phases for beneficial reuse of biosolids. The first phase proposed to use the existing sludge treatment system to produce biosolids for land application, composting, and soil mixing. In the second phase a new sludge treatment system with phosphorous and nitrogen recovery would produce a low-pathogen biosolids product that could be used by the public. The Master Plan proposed to construct the new sludge treatment system alongside the NEWPCC nutrient removal system so that the nutrients that were removed from the wastewater could be reused. This was done to comply with nutrient recovery and recycling requirements, to accelerate nutrient removal compliance, and for process stability. Nutrients removed from wastewater

---

<sup>3</sup> Manitoba Clean Environment Commission Supplement to An investigation into nutrient reduction and ammonia treatment

<http://www.cecmanitoba.ca/resource/Reports/nXp%20supplement%20final.pdf>

<sup>4</sup> Manitoba Water Protection Act: <https://web2.gov.mb.ca/laws/statutes/ccsm/w065e.php>

can have detrimental impacts on sludge treatment systems (e.g. phosphorous-based minerals can coat/accumulate within the system).

The Biosolids Master Plan was approved by Manitoba Sustainable Development in spring of 2016. In June 2016 the City informed Manitoba Sustainable Development that the NEWPCC Upgrade would not be completed by December 31, 2019. Manitoba Sustainable Development acknowledged receipt of this letter in August 2016.

In January 2016 the City hired AECOM to develop an enhanced preliminary design and Class 3 cost estimate for a nutrient removal and sludge treatment/nutrient recovery facility for the NEWPCC. After the preliminary design was completed the City determined that the estimated costs to comply with Provincial regulations were higher than originally budgeted. Due to these reasons and because of complexities and costs, it was recommended that the NEWPCC Upgrade for nutrient removal be broken into three projects and that the first phase, the Power Supply and Headworks Facilities, be approved to proceed. Council concurred with this recommendation on February 28, 2019 but added that the remaining two projects (which include beneficial reuse of nutrients and biosolids, and nutrient removal from NEWPCC wastewater) be prioritized subject to written confirmation of funding from the Federal and Provincial governments, impacts to rates, and licensing requirements.

### **Progress to Date in Nutrient Removal and Reuse**

The City provides quarterly reports and annual progress meetings to Manitoba Sustainable Development to give regular updates on nutrient removal compliance. The City has invested in \$402.8M in wastewater infrastructure upgrades at the NEWPCC, WEPCC, and SEWPCC. An additional \$408.4M is also expected to be spent in the first project for the NEWPCC, the North End Power Supply and Headworks Project.

The completed capital works at NEWPCC and WEPCC have resulted in an 18% reduction in total phosphorous loading, as shown in Figure 1 and a 14% reduction in nitrogen, compared to pre-upgrade levels. When the SEWPCC Upgrade is completed nutrient loading will reduce further, resulting in an estimated total phosphorous reduction of 30-35% respectively, compared to early-2000 levels. Nitrogen will have been reduced by 20-25%, compared to early 2000 levels.

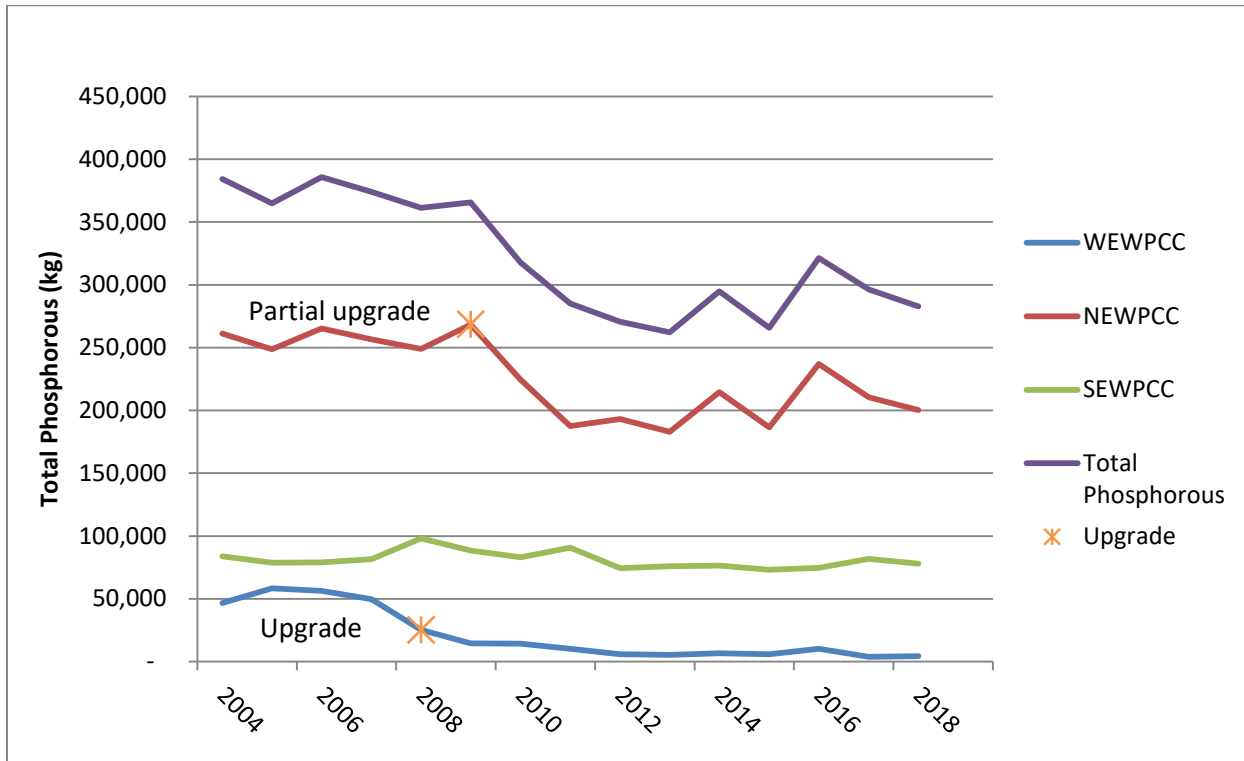

Figure 1 Kilograms of total phosphorous discharged from Winnipeg Sewage Treatment Plants from 2004 to 2018

In addition to this the City has implemented the first phase of the Biosolids Master Plan and has progressed annually in beneficial biosolids reuse. Figure 2 shows that the quantity of biosolids landfilled has been decreasing and that beneficial reuse options have been increasing.

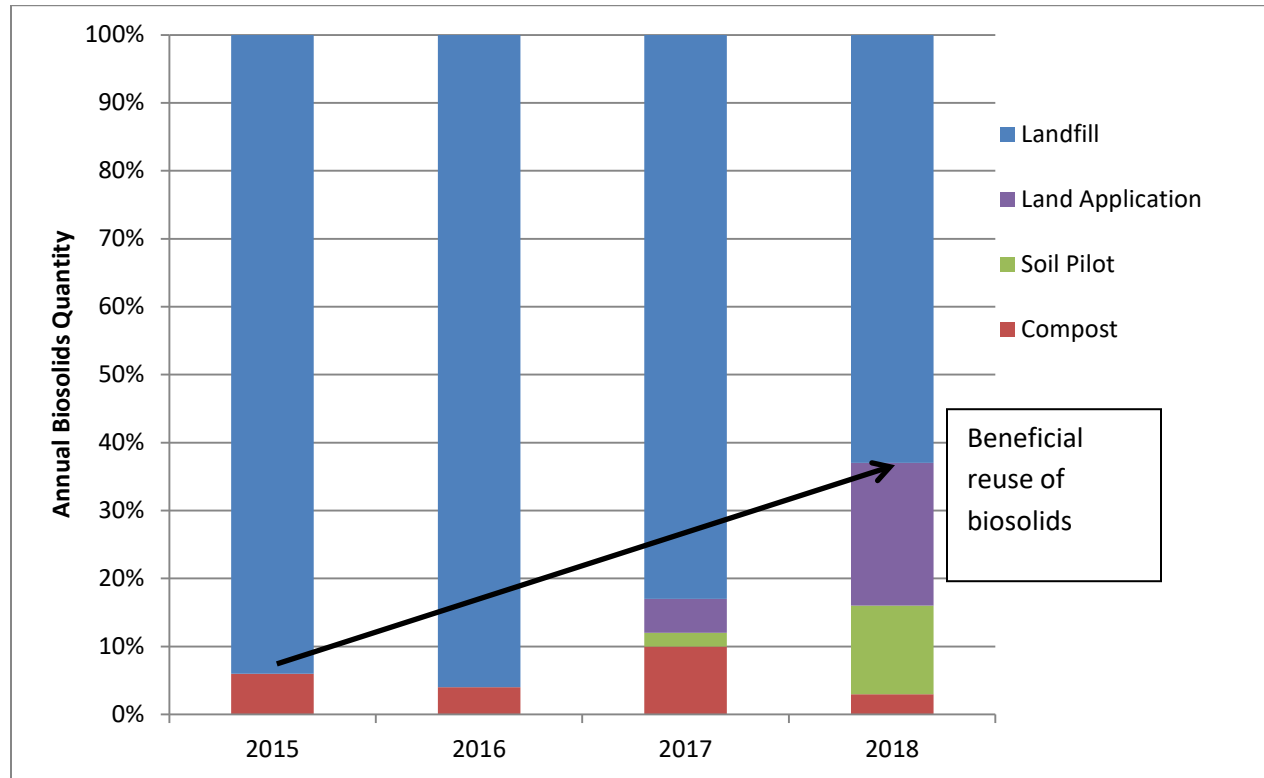

Figure 2 Biosolids disposal from 2015 - 2018

In 2018 approximately 37-38% of the City’s biosolids were beneficially reused through various programs. The Land Application Program provides free soil testing and biosolids delivery to willing farmers who then incorporate the biosolids into the soil as a conditioner and nutrient source. The soil manufacturing pilot uses biosolids, leftover road sweepings/gravel, and wood waste to create a soil that is used for top cover and erosion protection in Summit Landfill. The Biosolids Composting Program produces a low odour, low pathogen compost which is used for top cover and land remediation at Brady Road Resource Recovery Centre. The volume of biosolids that is beneficially reused is expected to grow as the land application program is optimized and the soil pilot program grows.

In addition to these programs the City also supports initiatives for research, water quality, and wastewater treatment with the following grants and memberships:

- Save Our Seine: annual \$30,000 grant to promote environmental protection and stewardship of the Seine River
- Lake Winnipeg Research Consortium: supporting member (\$60,000 annually) to promote research and understanding on issues critical to the health and wellbeing of Lake Winnipeg
- University of Manitoba Collaborative Research: annual \$30,000 grant with additional services-in-kind to support research into new and innovative wastewater treatment processes with an emphasis on improving treatment efficiency and biological nutrient removal
- Red River Basin Commission Netley-Libau Marsh Restoration Pilot Project: \$100,000 grant

## Review of Alternatives to Expedite Construction for NEWPCC

The original plan presented in the NEWPCC Master Plan was to construct all aspects of the headworks, biosolids, and nutrient removal components in parallel under one design-build contract. Due to project complexities and cost, it was recommended that the NEWPCC be divided into three major projects in order of process criticality, as funds become available. Some projects could be started as its predecessor is being designed and/or constructed. The order of projects is as follows:

1. Power Supply and Headworks, as already approved by City Council on February 28, 2019
2. Biosolids Facilities, start and completion date to be determined
3. Nutrient Removal Facilities, start and completion date to be determined

The dates of the second two projects are subject to Council approval. Nutrient removal cannot be implemented as the first project because of the limitations of the existing infrastructure. The existing sludge treatment system is not sized or designed to accommodate nutrient rich sludge. The phosphorous that is removed from the liquid wastewater is incorporated into the sludge solids and will mineralize in the sludge treatment system. This will reduce process pipping, reduce tankage capacity, and reduce capacity of the sludge treatment system. Chemicals can be added to prevent mineralization but this in turn generates a sludge which also decreases capacity. Some of the phosphorous may be removed from the sludge before the sludge treatment process but this would require new buildings and would not be a guaranteed protection.

The Biosolids Facility cannot proceed ahead of the existing headworks package because the new sludge treatment system has more stringent wastewater screening and grit removal requirements. These requirements would not be met until the existing screening and grit system is upgraded, which is part of the Power Supply and Headworks Upgrade.

## Review of Interim Alternatives for Phosphorous Removal

There has been recent interest in potential alternatives to biological phosphorous and nitrogen removal. Organizations such as the International Institute and Sustainable Development (IISD) and the Lake Winnipeg Foundation (LWF) have advocated for chemical phosphorous removal as an interim step to full biological nutrient removal. This technology will remove phosphorous from wastewater but does not comply with the Water Protection Act or the CEC recommendations for biological removal and recovery/recycling.

As part of this NOA request, the City has reviewed a variety of possible interim phosphorous removal options, including the recently proposed chemical phosphorous removal. Wastewater treatment is a complex and integrated process. One change can have multiple impacts throughout the process, which means that systems cannot be evaluated in isolation. For this reason AECOM was hired to conduct process risk reviews, mass balances, modeling, and sludge inventories in the following 8 scenarios:

1. Keep Existing System with No Changes
2. Side Stream Chemical Phosphorous Removal

3. Sidestream Struvite Crystallization
4. Chemical Phosphorous Removal using Ballasted Flocculation
5. Chemically Enhanced Primary Treatment (as proposed by IISD and LWF)
6. Chemical Phosphorous Removal in Existing High Purity Oxygen (HPO) reactors
7. Tertiary Phosphorous Removal from Effluent
8. Biological Phosphorous Removal only, with no nitrogen/ammonia removal (i.e. anaerobic tank in front of HPO reactors)

A description of each scenario is included in Appendix 1. The scenarios were reviewed with respect to phosphorous only. For evaluating risks and impacts 1 mg/L effluent phosphorous levels were targeted. Nitrogen and/or ammonia removal were not specifically considered though some processes may remove small quantities. Some scenarios, such as chemical dosing, would reduce the availability and reusability of phosphorous.

The review concluded that Scenario 1 at the NEWPCC is not recommended because this would lead to increases in phosphorus loading to the river and Lake Winnipeg. Phosphorous that is captured in the SEWPCC biological nutrient removal process will be hauled to the NEWPCC for sludge treatment and may then be released in the sludge treatment system. Scenario 3 would result in capital throw away costs that would not be used in the future because they wouldn't be coordinated with the future sludge treatment system. It would also not remove additional phosphorous but only maintain status quo. Scenarios 4, 5, 6, and 7 are also not recommended due to the amount inert solids that would be generated. The scenarios would generate an increase in 38-53% inert solids and would lead to overcapacity issues and instability in the sludge treatment system. Scenario 8 would, like the SEWPCC Upgrade, generate large quantities of phosphorous that would be re-released in the sludge treatment system. Capturing this phosphorous with chemicals would also lead to large quantities of inert sludge which would then lead to overcapacity and process instability in the sludge treatment system.

The City has seen substantial growth, as shown in Figure 3<sup>5</sup>, which has gradually consumed capacity of the City's sludge treatment system. The facility was last expanded in the early 1980's and has a finite capacity, with the existing sludge treatment system expected to reach capacity in the next 5-10 years.

---

<sup>5</sup> Population for the City of Winnipeg <https://winnipeg.ca/cao/pdfs/population.pdf>

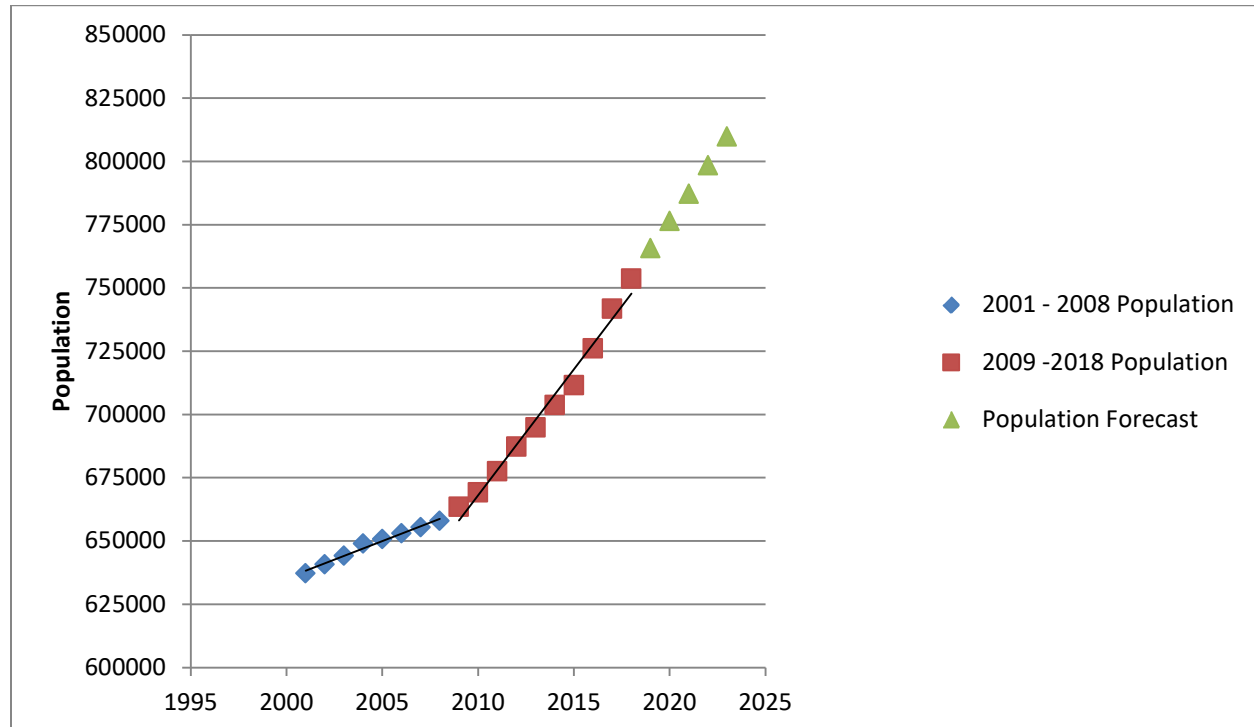

Figure 3 City of Winnipeg historical and forecasted population

In addition to residential growth there has been an increase in industrial applications from the food processing sector. This industry can have varied and very high strength waste; at the higher end a facility can generate an equivalent waste of 10,000 - 50,000 people. When these industries are brought online they further reduce the capacity of the sludge treatment system and limit the City's ability to consider options such as chemical phosphorous removal.

The AECOM memo concluded that the interim options to reduce phosphorous levels to 1 mg/L are not feasible because of the size and constraints of the existing sludge treatment system. The review recommended Scenario 2. Side Stream Chemical Phosphorous Removal to prevent phosphorous effluent levels from increasing. Phosphorous from the NEWPCC would not decrease significantly but would maintain pre-SEWPCC BNR concentrations. This will generate an inert sludge but the relative increase is small (approximately 5% increase in inert sludge) compared to the other scenarios. Capital costs for this scenario would include expanding the existing ferric chloride storage and dosing system. A system to monitor and adjust pH in the sludge treatment system would likely be required as well, to compensate for the additional ferric chloride dosing.

The AECOM memo also noted that a balance may be achieved between digester stability and partial phosphorous removal. A small quantity of ferric chloride may be dosed in Scenarios 5, 6, and 7 to reduce phosphorous levels, though not to 1 mg/L. While this would reduce the phosphorous loading to Lake Winnipeg it may also impact the lifespan of the sludge treatment system to less than the current 5-10 year estimate.

While some chemical phosphorous removal at NEWPCC may be possible it is recommended that it not be done until the SEWPCC is upgraded and the sludge treatment system is stably operating with SEWPCC BNR sludge. Interim chemical dosing will impact the sludge treatment system's capacity for future growth. It will also limit the ability to recycle and reuse nutrients, as the phosphorous will be chemically bound. Other parameters, such as nitrogen and ammonia, will not be addressed as part of this interim option and a phosphorous limit of 1 mg/L will not be achievable. This means that even if some interim phosphorous removal is possible the criteria described in the Water Protection Act would not be achieved.

## Next Steps

A process flow diagram, shown in Appendix 2 illustrates the next steps for the City's sewage treatment facilities. When the SEWPCC upgrade is completed Winnipeg's total phosphorous contribution will have decreased by 30-35% compared to the early 2000's. The City will continue progress on preparing the NEWPCC for future nutrient removal. This includes construction on the NEWPCC Power Supply Project, which will provide the necessary power for a nutrient removal facility. The NEWPCC Headworks Project, also a critical step towards nutrient removal, is in the procurement process and brings the City closer to its goal of full biological nutrient removal.

There is no committed date for NEWPCC biological phosphorous removal because the Biosolids Facilities and the Nutrient Removal Facilities projects have not been approved by Council and are subject to available funding. The City will explore opportunities for additional funding which may impact overall project schedule.

Interim phosphorous removal to 1 mg/L isn't feasible because of constraints in the existing sludge treatment system. The City proposes the following steps to determine if some interim-phosphorous removal is possible:

- Prepare the existing sludge treatment system to receive SEWPCC's nutrient rich sludge. This will be done so that the phosphorous captured in SEWPCC's wastewater process will not be released in the NEWPCC and will include expanding the ferric chloride dosing system and possible pH adjustment.
- Conduct testing and laboratory experiments to determine if some chemical phosphorous trimming could be implemented in the NEWPCC wastewater treatment plant. Trimming cannot be implemented before the SEWPCC is upgraded because the existing ferric dosing system will not have capacity for both the SEWPCC Upgrade and NEWPCC, and because the sludge treatment system must be stabilized with SEWPCC nutrient rich sludge before additional load can be placed on it
- Once the SEWPCC is upgraded and its sludge is stably treated in the City's existing sludge treatment system the City will review the findings of jar tests, laboratory piloting, and digester performance to determine if there is capacity for some trimming in NEWPCC.



The City will also explore up and coming alternative technologies that provide biological nutrient removal within a smaller footprint. Technologies, such as granular sludge, are not yet prevalent in mainstream full scale plants but the City has been supporting research in this area for several years in partnership with the University of Manitoba. With smaller footprints and operating costs there may be future opportunity to reduce the capital requirements to implement biological nutrient removal.

## Conclusion

While a completion date for the NEWPCC Upgrade is subject to funding constraints the City is still making progress by initiating the first major construction projects that will eventually lead to full biological nutrient removal. Some phosphorous may be removed through chemical trimming but because of constraints in the sludge treatment system the amount of phosphorous that can be removed will not meet the licence requirement of 1 mg/L.

The City is committed to doing its part to improve water quality in Manitoba. The capital program to upgrade its sewage treatment plants has resulted in less phosphorous to the river and this will decrease even further once the SEWPCC is upgraded to full biological nutrient removal. Since the early 2000's phosphorous effluent levels have been reduced by approximately 18%. When the SEWPCC Upgrade is complete total phosphorous effluent levels are projected to decrease by approximately 30-35%, compared to early 2000 levels. The Biosolids Program has also shown consistently increasing rates of beneficial reuse of biosolids and nutrients with 37-38% of biosolids being beneficially reused in 2018. Research that is currently being conducted at the City's facilities may lead to innovative alternatives and the City's continued support for local water quality groups and their initiatives will improve research and water quality.

Based on this report the City is requesting a two year extension to December 31, 2021 so that a plan for can be developed for future compliance.

## **Appendix 1 Memo: Temporary P Removal by AECOM, 2019**

**To:**  
Michelle Paetkau, P.Eng  
111 1199 Pacific Avenue  
Winnipeg MB R3E 3S8  
Canada

# Memo

**Subject: Temporary Phosphorus Removal at NEWPCC**

## 1. Background

The City of Winnipeg currently operates the North End Sewage Treatment Plant (NEWPCC) under Environment Act Licence No. 2684 RRR dated June 2009 that outlines the terms and conditions for the operation of the NEWPCC. The City has been granted a notice of alteration (NOA) to this licence which extends the date of compliance for the removal of nutrients from the NEWPCC effluent to December 31, 2019.

Based on the existing licence, for wastewater flows less than 380,000 m<sup>3</sup>/d the NEWPCC final effluent must not exceed the parameters listed in **Table 1**.

**Table 1: Existing NEWPCC Effluent Limits (Environmental Act Licence No. 2684 RRR)**

Parameter	Limit	Unit
cBOD	30	mg/L
TSS	30	mg/L
<i>Fecal Coliform</i>	200	Most probable number (MPN)/100 mL
<i>E. Coli</i>	200	Most probable number (MPN)/100 mL

The NEWPCC sidestream treatment SBR effluent is also regulated under Environment Act Licence No. 2684 RRR. The limits set for the SBR effluent are 119 kg/d of total phosphorus (TP), and 838 kg/d of total nitrogen (TN), both based on a 30 day rolling average.

The NEWPCC will be required to meet the final effluent quality listed in **Table 2** for all flow less than 705 ML/d.

**Table 2: Anticipated NEWPCC Effluent Limits**

<b>Parameter</b>	<b>Limit</b>	<b>Unit</b>	<b>Occurrence</b>
BOD	25	mg/L	98 <sup>th</sup> percentile
TSS	25	mg/L	98 <sup>th</sup> percentile
<i>E. Coli</i>	200	Most probable number (MPN)/100 mL	Monthly geometric mean
TP	1	mg/L	30-day rolling avg.
TN	15	mg/L	30-day rolling avg.
Ammonia	Variable	kg N/d	Daily

The current liquid treatment process in NEWPCC consists of raw sewage pumping, screening, grit removal, primary clarification, secondary treatment (high purity oxygen or HPO) reactors, secondary clarifiers, and disinfection using ultraviolet (UV) irradiation.

Sludge generated in the liquid stream (primary and waste secondary sludge) are co-thickened in the primary clarifiers prior to anaerobic digestion and dewatering. All sludge from the West End Water Pollution Control Centre (WEWPCC) and South End Water Pollution Control Centre (SEWPCC) are trucked to the NEWPCC for digestion and dewatering.

In 2021, the SEWPCC BNR Upgrade will be complete and the total phosphorus concentration in the effluent discharged to the Red River will be less than 1 mg/L. Some of the phosphorus removed from the wastewater will be retained in the waste secondary sludge and be transported to the NEWPCC for treatment. The impacts of this phosphorus are analyzed in this technical memorandum.

## **2. Objectives**

The objectives of this technical memorandum are to evaluate potential options of implementing interim phosphorus removal at the NEWPCC prior to construction of the NEWPCC Biological Nutrient Removal Upgrade Project. As part of this evaluation, feasibility level assessments will be prepared outlining the potential impact of these alternatives on downstream processes such as anaerobic digestion.

## **3. Existing NEWPCC Mass Balance**

To get a better understanding of the options available to the City, a phosphorus mass balance was conducted for the existing conditions at the NEWPCC. Currently sludge that is generated at WEWPCC and SEWPCC is trucked to the NEWPCC for processing. Since this sludge also contains phosphorus, it was included in the existing mass balance, and was based on data gathered from 2017-2018. Where data was not available, typical removal and performance values were assumed. As indicated in **Figure 1**, the phosphorus mass balance between the model and actual data was within 1 %, which for the purpose of this evaluation provides a good indication of the fate of phosphorus in the various liquid and solids streams at the NEWPCC. A summary of the mass balance including the sludge trucked from the WEWPCC and SEWPCC under average conditions is as follows:

#### Phosphorus Input to NEWPCC

- NEWPCC raw wastewater influent TP – 1,021 kg/d
- SEWPCC sludge TP – 197 kg/d
- WEWPCC Sludge TP – 125 kg/d

#### Phosphorus Outputs

- NEWPCC Effluent TP – 552 kg/d
- NEWPCC Biosolids to land TP – 802 kg/d
- Inputs (1,343 kg/d) – Outputs (1,354 kg/d) = 11 kg/d

#### SBR Effluent Recycle

- Centrate Recycle TP – 43 kg/d

As listed above the NEWPCC is currently discharging on average 43 kg/d of phosphorus in the SBR effluent, which is significantly better than the regulated limit of 119 kg/d of TP.

Mass Balance  
2017-2018  
(SEWPCC Sludge Fed Directly to Digesters)

-1%

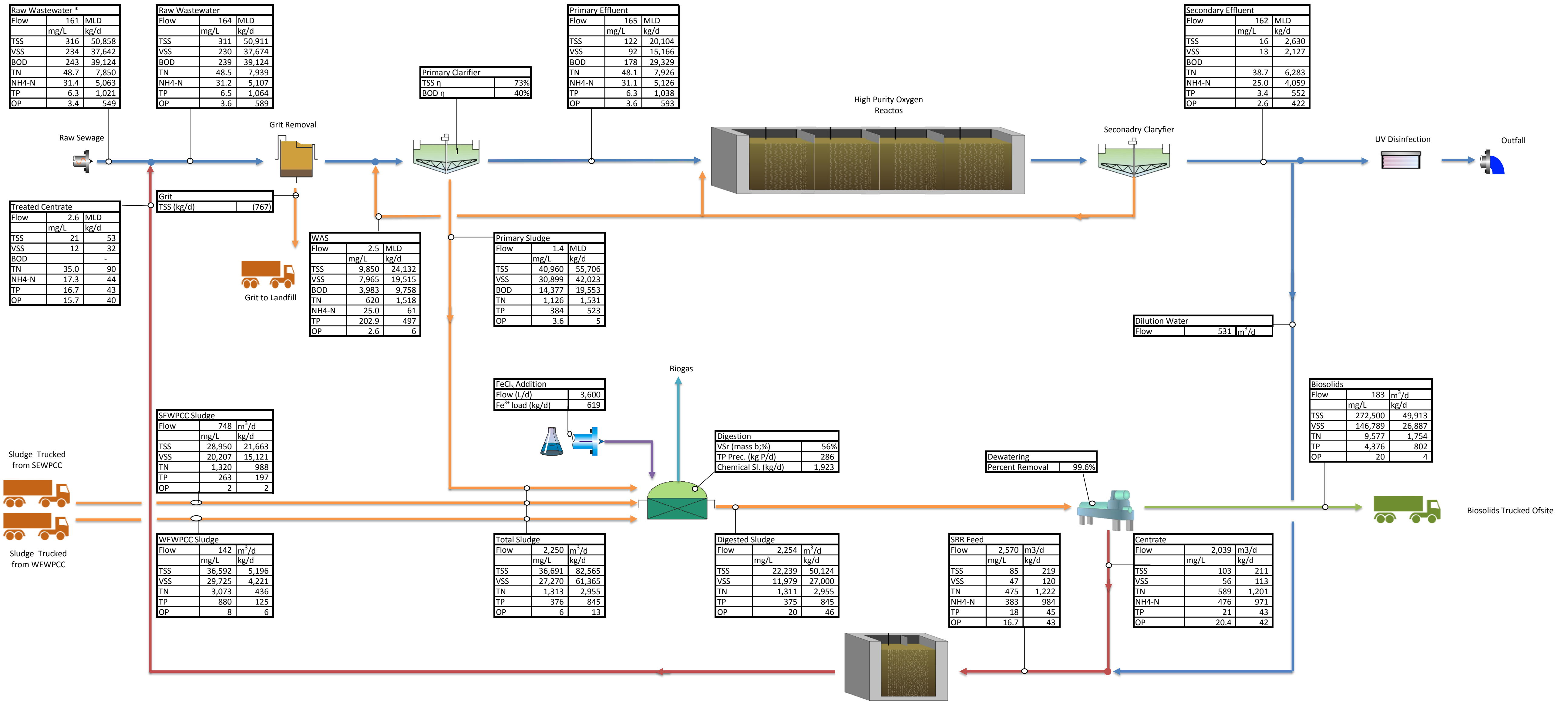

## 4. Potential Approaches for Temporary Phosphorus Removal

Based on the existing mass balance, a preliminary list of alternatives for removing phosphorus on a temporary basis was developed as follows:

- Existing System – No Change
- Sidestream Chemical Phosphorus Removal
- Sidestream Struvite Crystallization
- Chemical Phosphorus Removal Using Ballasted Flocculation
- Chemically Enhanced Primary Treatment
- Chemical Phosphorus Removal In HPO
- Tertiary Phosphorus Removal From Effluent
- Construct Anaerobic Tank In Front Of HPO Reactors

Each alternative is described in **Appendix A**, which includes a process description of the alternative, simplified schematic, a summary of the main features, brief evaluation of the technical criteria, operational criteria, and environmental criteria, along with a general indication of the impact of capital and operational costs. Following the summary tables a Mass Balance can be found for each Alternative.

At this conceptual stage, each alternative was evaluated based on the following assumptions:

- The analysis was limited to a discussion on phosphorus removal only. Nitrogen and ammonia were not considered although some processes may inadvertently remove these nutrients.
- All alternatives were evaluated using annual average loads. If an option is selected it should also be evaluated under maximum month loads.
- It was assumed the digester capacity at NEWPCC is limited to a VSS loading rate of 86,000 kg/d, and a minimum SRT of 15 days (all in service).
- For dosing of chemicals to the mainstream it was assumed that an effluent TP of less than 1 mg/L was desired. If a higher effluent TP concentrations are acceptable, then lower chemical dosing and less sludge production will result.
- For the chemical options the use of ferric chloride was assumed. There are several metal salts available, each with their own advantages and disadvantages that can be evaluated at the next stage. In this context, the term metal salts is used throughout this document.

The paragraphs below provide a general summary of each option evaluated. Further detail can be found in **Appendix A**.

### Alternative 1 – Existing System No Change

In 2021, the SEWPCC BNR Upgrade will be complete and the total phosphorus concentration in the effluent discharged to the Red River will be less than 1 mg/L. Some of the phosphorus removed from the wastewater will be retained in in the SEWPCC sludge and be transported to the NEWPCC for treatment. A mass balance for this option was prepared (**Appendix A**) and indicates that when the SEWPCC BNR upgrade is complete, the phosphorus in the SEWPCC sludge will increase by approximately 258 kg/d.

Based on the conditions in the NEWPCC digesters, the potential for nuisance struvite formation is high and will result in approximately 400 kg/d of nuisance struvite being generated. A portion of the additional phosphorus load from the SEWPCC biosolids will be recycled to the NEWPCC mainstream liquid stream process, and increase the secondary effluent total phosphorus concentration from the NEWPCC by about 250 kg/d or 45% (i.e, from 550 kg/d to 800 kg/d). The effluent from the NEWPCC sidestream SBRs will increase to about 298 kg/d (average). To accommodate the increased phosphorus load from the SEWPCC, an upgrade to the existing sidestream chemical system will be required.

### **Alternative 2 – Sidestream Chemical Phosphorus Removal**

In this option, the metal salt dose to digestion/dewatering will be increased to precipitate phosphorus and limit nuisance struvite formation. The amount of metal salts needed will double from the current use, from 619 kgFe/d, to 1,281 kgFe/d and will produce an additional 2,000 kg/d of chemical solids within the system, an overall increase of about 5%. The increased metal salt dose will prevent phosphorus from being returned to the NEWPCC liquid stream to below the current SBR effluent licence limit (i.e., 119 kgTP/d). This will also maintain the secondary effluent phosphorus discharge to the 2017/2018 concentrations. Higher chemical dosage could be used, but the maximum impact on the secondary effluent would be a reduction of phosphorus by about 10% from 2017/2018 levels. The increased dose of metal salts to the digester will consume approximately 1,500 kg/d of alkalinity, and therefore an alkalinity source will likely be required to maintain neutral conditions in the digesters. Preliminary modelling was conducted to confirm the amount of alkalinity needed, however, this should be verified with jar testing.

### **Alternative 3 – Sidestream Struvite Crystallization**

This option entails constructing a pre-digestion phosphorus release (WASSTRIP) process and a struvite recovery facility. The main advantage of this alternative is that phosphorus contained in the sludge from the WEWPCC and SEWPCC will be recovered prior to digestion, and reduce maintenance associated with nuisance struvite accumulation in digestion/dewatering. Similar to the previous chemical sidestream option, this alternative will maintain the NEWPCC secondary effluent TP loads to the 2017/2018 concentrations. The advantage to this alternative, is that alkalinity addition to the digesters would not be required.

### **Alternative 4 - Chemically phosphorus removal using ballasted flocculation**

The larger NEWPCC BNR Upgrade may include a ballasted flocculation process (i.e, Actiflo) for the treatment of wet weather flow. One option would be to construct this facility early and treat a portion of raw wastewater through this process to remove phosphorus to less than 1.5 mg/L. With an estimated 2023 flow of 192 ML/d, approximately 65% of the total flow (135 ML/d) would need to be directed through the ballasted flocculation system to achieve an overall final effluent TP of less than 1 mg/L. This option provides reduction of the final effluent concentration of the phosphorus but could increase the risk of scaling in the digesters, due to increased capture rate of phosphorus and nitrogen in the high rate clarification. Therefore, increased sidestream chemical dosing may also be needed. Following the larger NEWPCC BNR Upgrade, this facility would then act as a wet weather treatment as originally intended. Due to the large quantities of chemicals used, this alternative will generate an additional 7,300 kg/d of solids which will have a significant impact on digester operation and performance. With this increase in solids, the SRT of the digesters will need to operate below an SRT of 15 days which is below the recommended value for stable digester operation.



### **Alternative 5 - Chemically Enhanced Primary Treatment (CEPT)**

This option entails the addition of metal salts, sometimes with a polymer, to increase TSS, BOD, and TP removals in primary treatment. Metal salts precipitate phosphorus and would have to be monitored to ensure that phosphorus concentrations are not reduced to the point that it is not available for biological metabolism in secondary treatment. This can create conditions that promote the growth of filamentous organisms. The use of ferric chloride may also impact ultraviolet (UV) disinfection. Generally, dissolved iron concentrations less than 0.3 mg/L and total iron less than 1.0 mg/L do not pose a concern. For NEWPCC excess ferric would typically precipitate in the aeration basin and be removed in the secondary clarifiers.

Based on the mass balance, approximately 12 m<sup>3</sup>/d of metal salt dosed into the primary clarifier will be needed to reduce the secondary effluent total phosphorus to below 1 mg/L. In this option nuisance struvite formation (400 kg/d) would still occur due to the increased phosphorus content of the SEWPCC biosolids, so it would be recommended to increase the metal salt dose in the sidestream as well as the mainstream.

Similar to Alternative 4, this alternative will generate large amounts of additional solids (approximately 5,600 kg/d) under average conditions which will have a significant impact on digester operation and performance. With this increase in solids, the SRT of the digesters would need to operate near the recommended minimum solids retention time (SRT) limit of 15 days, with the City being at risk if a digester needs to be removed from service for maintenance. At maximum month load conditions which is typical of digester design, the risk associated with digester performance would be even more pronounced.

### **Alternative 6 - Chemical Phosphorus Removal in HPO**

This entails adding metal salts to the HPO reactors or to the secondary clarifier influent, allowing the phosphorus to be precipitated within the mixed liquor. This option could be used in conjunction with chemically enhanced primary treatment (CEPT), that is, removing a portion of the phosphorus in primary treatment, and polishing in the secondary process. Approximately 12 m<sup>3</sup>/d of metal salt would be needed to reduce the secondary effluent total phosphorus to less than 1 mg/L. Since the chemical is dosed to the secondary process, it will increase the mixed liquor concentration by about 500 mg/L. This in-turn will increase the clarifier solids loading rate. In this option, nuisance struvite formation is expected in the dewatering process, so it is also recommended that the metal salt dose to the digesters be increased.

Similar to Alternative 5, this alternative will generate large amounts of solids (approximately 5,600 kg/d) which will have a significant impact on digester operation and performance. With this increase, the SRT of the digesters would need to operate near the recommended minimum SRT limit of 15 days, with the City being at risk if a digester needs to be removed from service. In addition to this risk, the additional inert solids will raise the MLSS concentration in the HPO reactors by approximately 500 mg/L. This could result in performance issues of the secondary clarifiers due to the resulting increase in solids loading rate.

### **Alternative 7 - Tertiary Phosphorus Removal from Effluent**

As an alternate to ballasted flocculation, the City is also considering the AquaPrime® cloth media filter for treating wet weather flows. If chosen, this filter would be configured to treat raw wastewater flow during wet weather events, or secondary effluent during normal flow periods. The filtration unit could be constructed ahead of schedule, and used to provide tertiary phosphorus removal on the secondary effluent. This would involve dosing approximately 15 m<sup>3</sup>/d of metal salt upstream of the filters to maintain an effluent TP less than 1 mg/L. This would generate about 6,300 kg/d of chemical sludge that would either be backwashed

back to the primary clarifiers, or thickened separately and blended with the thickened sludge sent to the digesters.

Similar to the other mainstream alternatives, this alternative will generate large amounts of solids (approximately 8,600 kg/d), and therefore, exceed the capacity of the digesters.

### **Alternative 8 - Construct Anaerobic Tank in Front of HPO Reactors**

In this option, an anaerobic reactor would be constructed to accept return activated sludge (RAS) from the secondary clarifiers. When this anaerobic zone is placed upstream of the HPO reactors, conditions exist for biological phosphorus removal. To prevent the re-release of phosphorus, co-thickening of WAS will need to be discontinued and a separate WAS thickening system constructed. Since all phosphorus is taken up biologically, it will also be released during anaerobic digestion. To break the phosphorus loop, approximately 12 m<sup>3</sup>/d of metal salt will need to be added to the digesters/dewatering. Overall sludge production would increase by about 13% as compared to Alternative 1. Due the increased dose of metal salts to the digester, alkalinity will be consumed, and therefore pH control will likely be required to maintain neutral conditions in the digesters.

## **5. Evaluation of Alternatives**

In **Appendix A** the impacts of each alternative were assessed based on technical, operational, and environmental criteria. As well a general impact of capital and operational costs were indicated. On March 12, 2019 AECOM met with the City to discuss this assessment. A summary of alternatives evaluation presented at this meeting are summarized below.

**Alternative 1 (Existing System No Change)** is not recommended. The increase in phosphorus rich sludge from the SEWPCC will create nuisance struvite issues at NEWPCC increasing digester/dewatering shut downs, and will increase the SBR effluent above the phosphorus licence limit of 119 kg/d. This increased phosphorus from the SBRs will be ultimately transferred to the mainstream, and increase the NEWPCC secondary effluent phosphorus load.

**Alternative 2 (Increase Sidestream Chemical Removal)** was considered a feasible alternative. This option will maintain the SBR effluent TP limits within the regulatory limit and maintain the NEWPCC secondary effluent at 2017/2018 concentrations. The amount of metal salt needed will double from the current requirement, which will also likely trigger the need for digester pH control. Jar testing will be needed to confirm the amount of chemical need for pH control. The current chemical storage system will likely need to be upgraded to accommodate the increased chemical usage.

**Alternative 3 (Sidestream Struvite Crystallization)** was deemed feasible, however, due to the location of the digesters in this alternative (Parcel A) it will be difficult to coordinate the location of the struvite crystallization facility with the full BNR Upgrade where the digesters will be located on Parcel B. For this reason Alternative 3 was not considered further.

**Alternatives 4, 5, 6, and 7** are alternatives that involve dosing chemicals to the NEWPCC mainstream. These alternatives generate significant amounts of solids which will create digester capacity issues. Specifically, the anaerobic digester SRT will need to be reduced below 15 days which will lead to digester instability. For these reasons, these alternatives were not considered feasible. It should be noted that these alternatives were evaluated based on meeting a secondary effluent TP concentration of less than 1

mg/L. If higher secondary effluent TP concentrations are acceptable, then these options could be re-evaluated as the inert solids generation will be less.

**Alternative 8 (Biological Phosphorus Removal)** will lead to a large amount of chemicals needed to prevent the phosphorus from being released in the sidestream. The metal salt dose to the sidestream will increase to 12 m<sup>3</sup>/d and generate an increase in inert solids. In addition to the increase in chemicals, a significant capital expenditure for new reactor tankage, and WASSTRIP tanks will be required. The location of these tanks are not compatible with the ultimate NEWPCC BNR Upgrade. For these reasons, Alternative 8 was not considered further.

## 6. Recommendation

Based on AECOM's evaluation and the meeting with the City Water and Waste Department on March 12, 2019 it is recommended to carry forward Alternative 2 - Sidestream Chemical Phosphorus Removal for more detailed evaluation. It is recognized that the current chemical delivery (rail), storage, and dosing system at the NEWPCC may have limitations given the metal salt requirement is expected to double from the current consumption. The increased metal salt dose will also reduce the amount of alkalinity in the digester by about 1,500 kg/d and therefore, pH adjustment may be necessary. Preliminary modelling confirmed the need for pH adjustment, however, this should be verified with jar testing. Implementing Alternative 2 could lead to a net overall reduction of approximately 10 % phosphorus discharged from the NEWPCC. However, it should be recognized that this will generate an additional 2000 kg/d of chemical sludge.

Meeting a final effluent concentration of less than 1.0 mg/L is not possible given the limitations of the existing system, specifically the digester capacity. However, for Alternatives 5 and 6 it could be possible to incrementally lower the secondary effluent phosphorus load by dosing small amounts of metal salts to the primary and secondary treatment system. This would require the City to implement a trial program whereby the effluent phosphorus is removed in small increments over a period of time so that any potential adverse impacts can be identified and mitigated.



Keith Sears, P.Eng. PhD.  
Project Engineer



**AECOM**

**Appendix A**

Two thin black lines intersect on a white background. One line has a shallow positive slope, while the other has a steeper positive slope. They cross each other in the left half of the image.

**Existing System - No Change**

<b>ALTERNATIVE 1</b>	<b>EXISTING SYSTEM – NO CHANGE</b>
<b>STANDARD:</b>	Effluent TP – Increases by 45% from current levels

**PROCESS DESCRIPTION**

This option assumes continued operation of the facility without any changes to the plant configuration, and no increase in chemical addition to the sidestream process at the NEWPCC. Due to the implementation of BNR at the SEWPCC, approximately 450 kg/d of phosphorus will be transported within the biosolids to the NEWPCC. This additional phosphorus load will result in about 400 kg/d of nuisance struvite formation within the digestion/dewatering processes.

The sidestream SBR decant will contain higher levels of phosphorus (298 kg/d) which will be above the licence limit of 119 kg/d. This will be returned to the NEWPCC mainstream and increase the secondary effluent total phosphorus load by about 45% from current levels, from 550 kg/d to 800 kg/d.

A process flow schematic of the proposed upgrade of the NEWPCC to CEPT is presented in **Figure 1**.

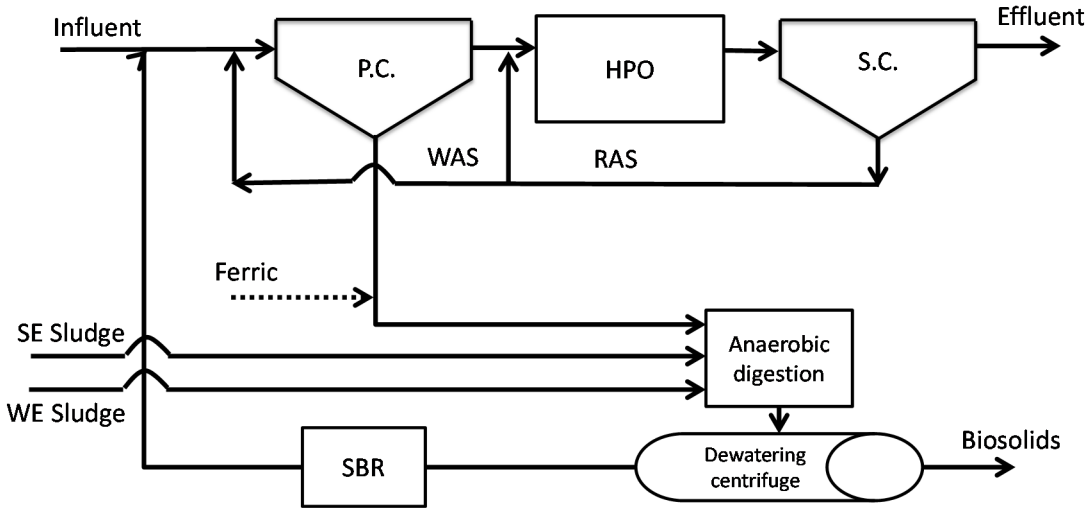

**Figure 1: Existing System No Change**

Mass Balance  
2023  
Existing System No Change

0%

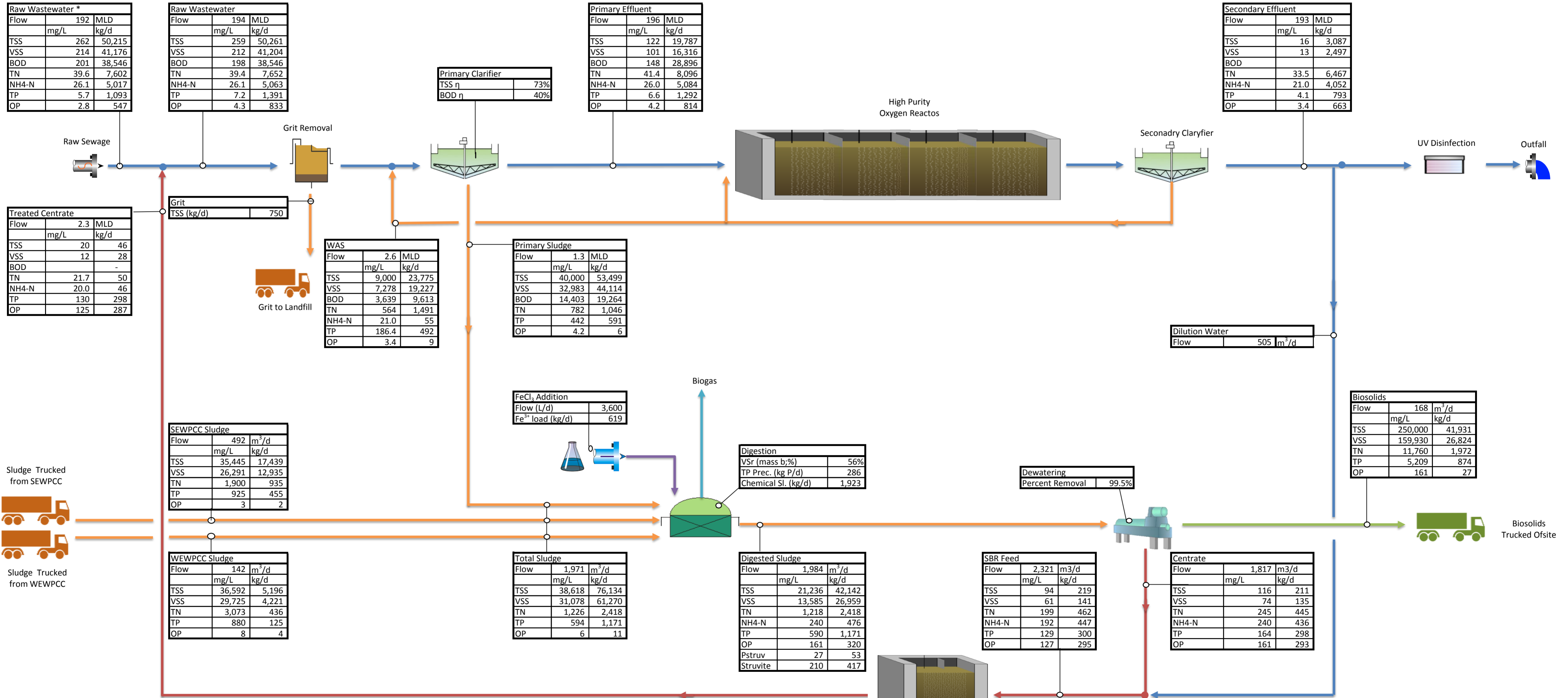

Raw Wastewater*		
Flow	mg/L	MLD
Flow	192	MLD
TSS	262	50,215
VSS	214	41,176
BOD	201	38,546
TN	39.6	7,602
NH4-N	26.1	5,017
TP	5.7	1,093
OP	2.8	547

Raw Wastewater		
Flow	mg/L	kg/d
Flow	194	MLD
TSS	259	50,261
VSS	212	41,204
BOD	198	38,546
TN	39.4	7,652
NH4-N	26.1	5,063
TP	7.2	1,391
OP	4.3	833

Primary Effluent		
Flow	mg/L	kg/d
Flow	196	MLD
TSS	122	19,787
VSS	101	16,316
BOD	148	28,896
TN	41.4	8,096
NH4-N	26.0	5,084
TP	6.6	1,292
OP	4.2	814

Secondary Effluent		
Flow	mg/L	MLD
Flow	193	MLD
TSS	16	3,087
VSS	13	2,497
BOD		
TN	33.5	6,467
NH4-N	21.0	4,052
TP	4.1	793
OP	3.4	663

Treated Centrate		
Flow	mg/L	MLD
Flow	2.3	MLD
TSS	20	46
VSS	12	28
BOD		
TN	21.7	50
NH4-N	20.0	46
TP	130	298
OP	125	287

Grit	
Flow	TSS (kg/d)
Flow	750

WAS		
Flow	mg/L	MLD
Flow	2.6	MLD
TSS	9,000	23,775
VSS	7,278	19,227
BOD	3,639	9,613
TN	564	1,491
NH4-N	21.0	55
TP	186.4	492
OP	3.4	9

Primary Sludge		
Flow	mg/L	MLD
Flow	1.3	MLD
TSS	40,000	53,499
VSS	32,983	44,114
BOD	14,403	19,264
TN	782	1,046
TP	442	591
OP	4.2	6

FeCl <sub>3</sub> Addition	
Flow (L/d)	Fe <sup>3+</sup> load (kg/d)
Flow (L/d)	3,600
Fe <sup>3+</sup> load (kg/d)	619

Digestion	
Vsr (mass b;%)	Chemical Sl. (kg/d)
Vsr (mass b;%)	56%
TP Prec. (kg P/d)	286
Chemical Sl. (kg/d)	1,923

Dewatering	
Percent Removal	
Percent Removal	99.5%

Biosolids		
Flow	mg/L	m <sup>3</sup> /d
Flow	168	m <sup>3</sup> /d
TSS	250,000	41,931
VSS	159,930	26,824
TN	11,760	1,972
TP	5,209	874
OP	161	27

SEWPCC Sludge		
Flow	mg/L	kg/d
Flow	492	m <sup>3</sup> /d
TSS	35,445	17,439
VSS	26,291	12,935
TN	1,900	935
TP	925	455
OP	3	2

WEWPC Sludge		
Flow	mg/L	m <sup>3</sup> /d
Flow	142	m <sup>3</sup> /d
TSS	36,592	5,196
VSS	29,725	4,221
TN	3,073	436
TP	880	125
OP	8	4

Total Sludge		
Flow	mg/L	m <sup>3</sup> /d
Flow	1,971	m <sup>3</sup> /d
TSS	38,618	76,134
VSS	31,078	61,270
TN	1,226	2,418
TP	594	1,171
OP	6	11

Digested Sludge		
Flow	mg/L	m <sup>3</sup> /d
Flow	1,984	m <sup>3</sup> /d
TSS	21,236	42,142
VSS	13,585	26,959
TN	1,218	2,418
NH4-N	240	476
TP	590	1,171
OP	161	320
Pstruv	27	53
Struvite	210	417

SBR Feed		
Flow	mg/L	kg/d
Flow	2,321	m <sup>3</sup> /d
TSS	94	219
VSS	61	141
TN	199	462
NH4-N	192	447
TP	129	300
OP	127	295

Centrate		
Flow	mg/L	m <sup>3</sup> /d
Flow	1,817	m <sup>3</sup> /d
TSS	116	211
VSS	74	135
TN	245	445
NH4-N	240	436
TP	164	298
OP	161	293

**NEWPCC – Existing System No Change (Cont'd.)**

<b>PROCESS DESCRIPTION (Cont'd.)</b>	
<p><b>Main Features for “Existing System No Change” Option</b></p> <p>Exceed current SBR effluent phosphorus licence limit.</p> <p>Increase in secondary effluent TP by 45% from current levels.</p> <p>Significant risk of struvite scaling in digesters, dewatering and SBRs</p>	
<b>TECHNICAL CRITERIA</b>	
<b>1. Reliability:</b>	Increased nuisance struvite generation will reduce the overall reliability of digestion/dewatering processes due to increased maintenance requirements.
<b>2. Robustness:</b>	The concept of metal salt addition to sidestream processes is considered robust. However, due to the increase in nuisance struvite formation in the digester/dewatering systems that will create operational issues, this option should be considered a reduction of robustness from current levels.
<b>3. Flexibility:</b>	In this base case alternative, operations staff have limited ability to address increased phosphorus load from the SEWPCC. Therefore, this option is not considered flexible.
<b>4. Impact on Other Parts of the Plant:</b>	Overall, nuisance struvite formation will increase maintenance activities associated with the dewatering process. This may lead to increase centrifuge maintenance, pipe blockages, and digester shutdowns.
<b>5. Space Requirements:</b>	There is no change to the existing space requirements.
<b>6. Compatibility with Future BNR:</b>	The future BNR upgrade will likely have a chemical phosphorus back-up system. It is envisioned that the existing chemical storage system will form part of the ultimate BNR build out.
<b>7. Constructability:</b>	This alternative requires no construction.
<b>OPERATIONAL CRITERIA</b>	
<b>1. Ease of Operation:</b>	This option uses the existing sidestream phosphorus removal system. There is no change in the operation.
<b>2. Ease of Maintenance:</b>	Maintenance will increase due to the formation of nuisance struvite in the digesters and dewatering system. This will increase the maintenance activities and the number of units taken off-line for servicing.
<b>3. Operator Safety:</b>	Plant staff already use ferric chloride. They have been provided special training to minimize the risk of an incident.
<b>ENVIRONMENTAL AND AESTHETIC CRITERIA</b>	
<b>1. Traffic:</b>	No change in traffic from existing.
<b>2. Noise:</b>	There will be no increase in noise.
<b>3. Visual:</b>	The will be no visual changes.



## NEWPCC – Existing System No Change (Cont'd.)

<b>4. Odours:</b>	There would be no noticeable difference in odour.
<b>COST CRITERIA</b>	
<b>1. Capital Cost:</b>	There is no cost for this option.
<b>2. Operating and Maintenance Costs:</b>	Additional O&M costs are associated with the increase in maintenance from struvite.

Two thin black lines intersect at a point in the upper-left quadrant of the page. One line slopes steeply upwards from the bottom-left towards the top-right. The other line slopes more gradually upwards from the bottom-left towards the top-right, crossing the first line.

**Increase Sidestream  
Chemical P Removal**

<b>ALTERNATIVE 2</b>	<b>INCREASE SIDESTREAM CHEMICAL PHOSPHORUS REMOVAL</b>
<b>STANDARD:</b>	Maintain Secondary Clarifier Effluent TP to 2017/2018 Levels

**PROCESS DESCRIPTION**

In this option, the metal salt dose to digestion/dewatering will be increased to precipitate phosphorus and limit nuisance struvite formation. The amount of metal salts needed will double from the current use, from 619 kgFe/d, to 1,281 kgFe/d. This will produce an additional 2,000 kg/d of chemical solids within the system, an overall increase of about 5 percent. The increased metal salt dose will prevent phosphorus contained in the SEWPC biosolids from being returned to the NEWPCC liquid stream and maintain the secondary effluent phosphorus loading to the 2017/2018 levels. The high ferric chloride dose may result in pH depression in the digestion and require pH adjustment. Higher chemical dosage could be used, but the maximum impact on the secondary effluent would be a reduction of phosphorus by about 10% from 2017/2018 levels.

A process flow schematic of the proposed upgrade of the NEWPCC to CEPT is presented in **Figure 2**.

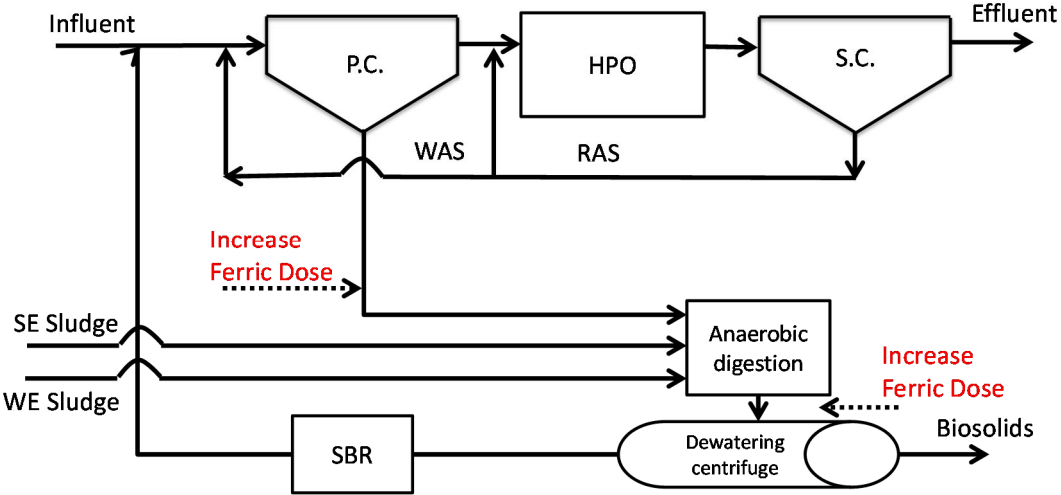

**Figure 2: Increase Sidestream Chemical Phosphorus Removal**

# Mass Balance 2023 Increase Sidestream Chemical Phosphorus Removal

1%

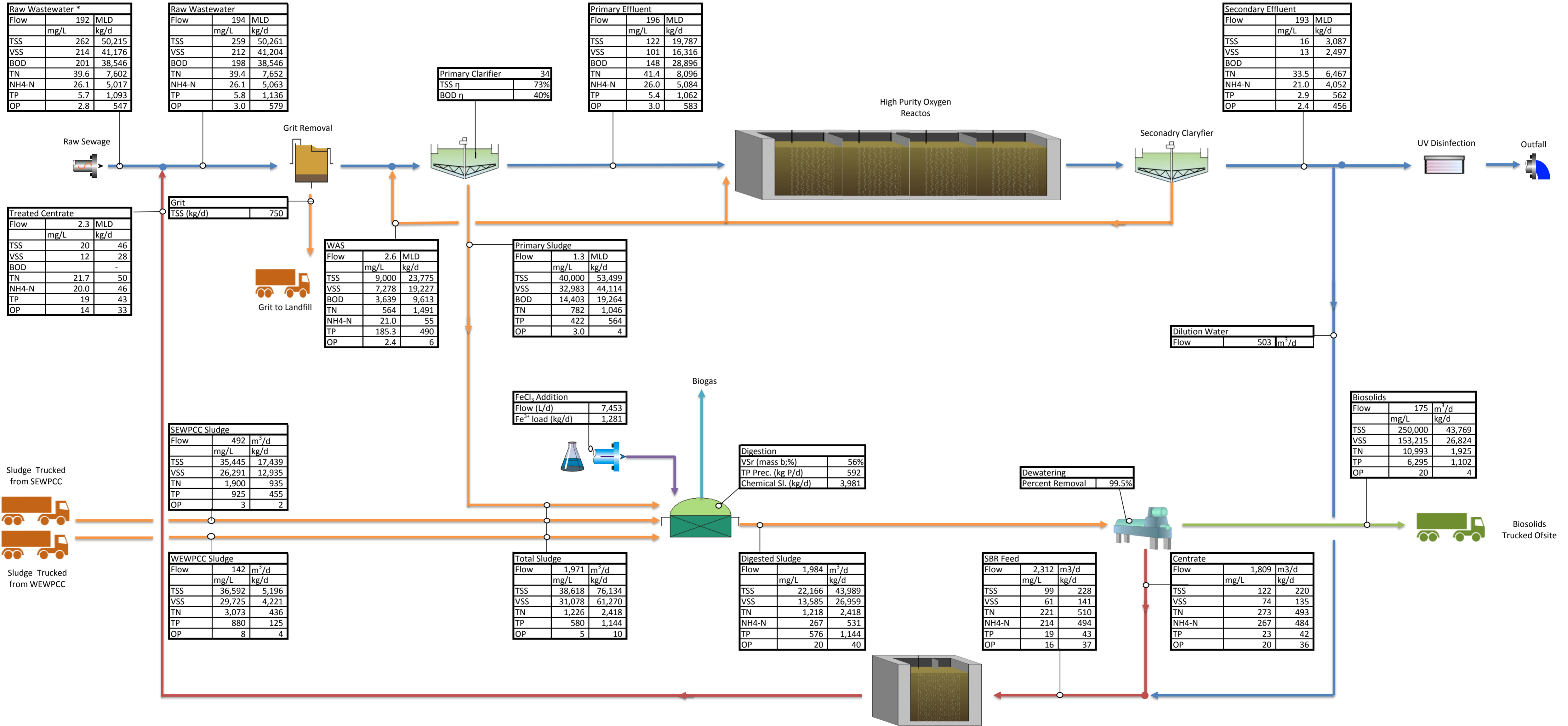

## NEWPCC – Increase Sidestream Chemical Phosphorus Removal (Cont'd.)

<b>PROCESS DESCRIPTION (Cont'd.)</b>	
<b>Main Design Features of Increase Sidestream chemical phosphorus removal</b>	
<ul style="list-style-type: none"> <li>- Increased ferric dose to the digester feed 7.5 m<sup>3</sup>/d (1300 kg Fe/d)</li> <li>- Decrease of the final effluent phosphorus load by 230 kg/d (in comparison with the base case)</li> <li>- Increase load of inert solids to the digesters 2,000 kg/d (in comparison with the base case)</li> <li>- Minimized risk of scaling in the digesters and downstream processes</li> <li>- May require the need for pH control (to be determined through jar tests)</li> </ul>	
<b>TECHNICAL CRITERIA</b>	
<b>1. Reliability:</b>	The City has been dosing ferric chloride to the digesters/dewatering since 2006. This alternative is simply an adjustment to the chemical dose rate to remove more phosphorus, offsetting the increased phosphorus load coming from the SEWPCC. It is considered a reliable method of sidestream phosphorus removal. One of the critical factors will be delivery of chemicals. Currently the NEWPCC has 2 x 70 m <sup>3</sup> storage tanks, providing approximately 2 weeks of storage at the proposed dose rate.
<b>2. Robustness:</b>	Equipment such as the chemical metering pumps used at the NEWPCC and chemical storage are considered robust.
<b>3. Flexibility:</b>	Operations staff can change chemical dose based on required effluent quality. This alternative does not provide the ability to reduce the secondary effluent phosphorus concentration below 2.0 mg/L.
<b>4. Impact on Other Parts of the Plant:</b>	The addition of chemicals to the digestion/dewatering process will increase the overall sludge quantities generated at the NEWPCC. Overall, sludge production will increase by about 5 percent. This is not expected to exceed the capacity of the existing digesters, may reduce capacity when digesters are taken out of service.
<b>5. Space Requirements:</b>	If the existing chemical storage tanks are used, this alternative will require no additional space.
<b>6. Compatibility with Future BNR:</b>	The future BNR upgrade will incorporate a struvite recovery system. However, sidestream chemical back-up for sulphide control will be maintained. Therefore, this system can be incorporated into the future build-out.
<b>7. Constructability:</b>	This alternative requires no construction.
<b>OPERATIONAL CRITERIA</b>	
<b>1. Ease of Operation:</b>	Positive displacement chemical dosing pumps are already used at the NEWPCC to feed ferric chloride to the digestion/dewatering process. Therefore, minimal changes are expected.
<b>2. Ease of Maintenance:</b>	Maintenance would be relatively straightforward and typical of equipment maintenance requirements.

## NEWPCC – Increase Sidestream Chemical Phosphorus Removal (Cont'd.)

<b>3. Operator Safety:</b>	Plant staff is already using ferric chloride, and therefore, are aware of the inherent risks associated with it's use. Continued training should be given to minimize the risk of an incident and to properly deal with an incident should one occur.
<b>ENVIRONMENTAL AND AESTHETIC CRITERIA</b>	
<b>1. Traffic:</b>	There will be additional deliveries for the delivery of metal salts and a small increase in biosolids disposal traffic (5%).
<b>2. Noise:</b>	The will be no increase in noise.
<b>3. Visual:</b>	The will be no visual changes.
<b>4. Odours:</b>	There would be no noticeable difference in odour from the current levels.
<b>COST CRITERIA</b>	
<b>1. Capital Cost:</b>	A review of the chemical dosing pump capacity may indicate a need for new chemical feed pumps, however, these cost are considered minor.
<b>2. Operating and Maintenance Costs:</b>	Additional O&M costs are associated with the increase in chemical use and sludge processing.



**Sidestream Struvite  
Crystallization**

<b>ALTERNATIVE 3</b>	<b>SIDESTREAM STRUVITE CRYSTALLIZATION</b>
<b>STANDARD:</b>	Maintain Section Effluent to 2017/2018 Levels

**PROCESS DESCRIPTION**

This option entails constructing a pre-digestion phosphorus release (WASSTRP) process and a struvite recovery facility. The main advantage of this alternative is that phosphorus contained in the sludge from the WEWPC and SEWPC will be recovered prior to digestion, and reduce maintenance associated with nuisance struvite accumulation in digestion/dewatering. Similar to the previous chemical sidestream option, this alternative will maintain the NEWPC secondary effluent TP loads to the 2017/2018 levels.

A process flow schematic of the proposed upgrade of the NEWPC is presented in **Figure 3**.

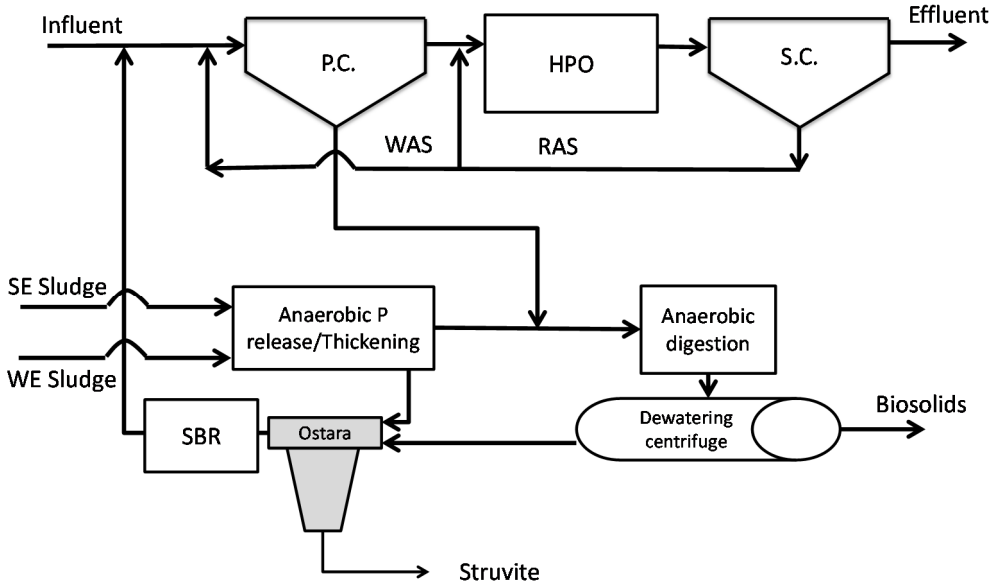
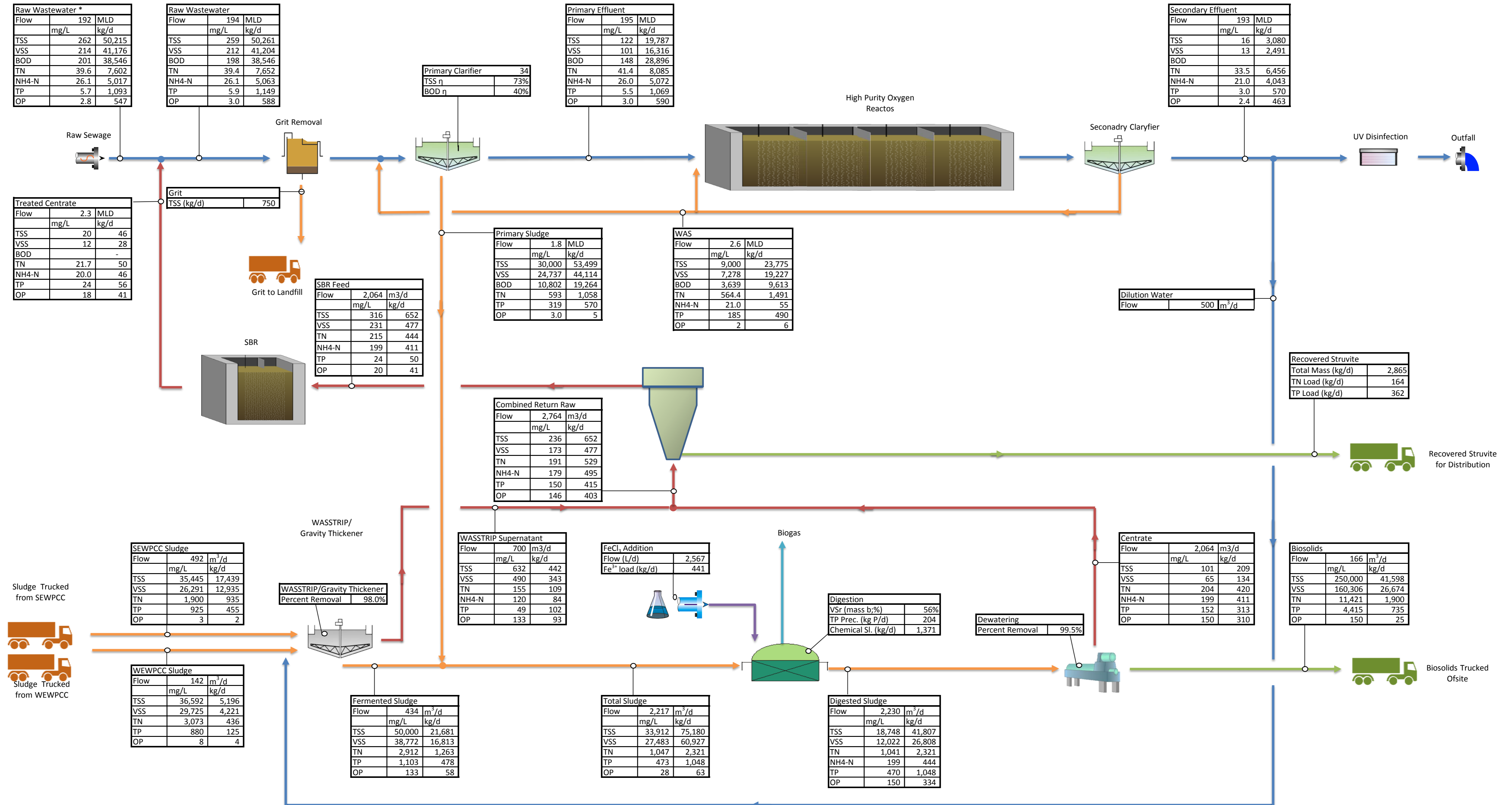

**Figure 3: Sidestream Struvite Crystallization**



# Mass Balance 2023 Sidestream Struvite Crystallization

0%



## NEWPCC – Sidestream Struvite Crystallization (Cont'd.)

<b>PROCESS DESCRIPTION (Cont'd.)</b>	
<b>Main Features for Sidestream Struvite Crystallization</b>	
<ul style="list-style-type: none"> <li>- 24 hour sludge holding tank and thickening added for the hauled sludge</li> <li>- Daily struvite recovery at 3,000 kg/d (360 kg P/d)</li> <li>- Ferric dose to the digesters maintained at the current level of 3.6 m<sup>3</sup>/d (620 kg Fe/d)</li> <li>- Final effluent phosphorus load decreased by 220 kg/d (in comparison with the base case)</li> <li>- No change in digester loading rate or in biosolids production (in comparison with the base case)</li> <li>- Minimized risk of scaling in the digesters and downstream processes</li> </ul>	
<b>TECHNICAL CRITERIA</b>	
<b>1. Reliability:</b>	<p>The phosphorus release in the WASSTRIP tank upstream of the digester relies on the temperature and availability of the volatile fatty acids (VFA). Field studies conducted by Ostará using WEWPCC sludge, indicated that up to 24 hours of sludge retention is sufficient for maximum release of stored phosphorus.</p> <p>The struvite crystallization process depends largely on the use of magnesium and sodium hydroxide for struvite generation. These are readily available. Both the phosphorus release and the struvite crystallization process are considered reliable.</p>
<b>2. Robustness:</b>	<p>The phosphorus release tank will contain submersible mixers, and be followed by a thickening unit such as a rotary drum thickener. Additional sludge pumping is required. This process relies on various mechanical equipment, and will require a level of redundancy to maintain overall robustness.</p> <p>Due to the limited number of mechanical parts, repairs may be fairly quick and the struvite crystallization process may be designed with limited or no redundancy. Scheduled maintenance for descaling the crystallizer is the main activity required. Other equipment such as the chemical metering pumps and chemical storage are considered robust.</p>
<b>3. Flexibility:</b>	<p>There will be some flexibility in the operation of the phosphorus release units in terms of sludge SRT and effluent sludge thickness which may be useful for balancing the fed to the digesters.</p> <p>Struvite recovery requires relatively precise control. Struvite production almost entirely depends on the incoming load of phosphorus.</p>
<b>4. Impact on Other Parts of the Plant:</b>	<p>The phosphorus release units will remove phosphorus prior to the digesters minimizing the risk of scaling in the digesters, dewatering and SBRs. Struvite recovery will limit the return load of phosphorus to the mainstream, lowering the overall secondary effluent load.</p>

## NEWPCC – Sidestream Struvite Crystallization (Cont'd.)

<b>5. Space Requirements:</b>	This option has relatively large space requirements. A new building for struvite recovery and new process tank for the phosphorus release is required.
<b>6. Compatibility with Future BNR:</b>	Both phosphorus release units and the struvite crystallization system are part of the planned future BNR plant upgrade. However, it was envisioned they would be constructed on Parcel B.
<b>7. Constructability:</b>	New structures would be required. The space is available between the existing digesters and SBRs.
<b>OPERATIONAL CRITERIA</b>	
<b>1. Ease of Operation:</b>	The operation of phosphorus release units will be automated, however, regular attention and monitoring by staff will be needed. The type equipment used should be familiar to City operators.  The struvite recovery process will require about a 0.5 full-time equivalent operator for daily operational checks, product bagging and quality testing. Ostara typically provides remote monitoring.
<b>2. Ease of Maintenance:</b>	Increased amount of mechanical equipment will increase maintenance requirements. Most of the equipment is already familiar to the City operators.
<b>3. Operator Safety:</b>	Struvite recovery systems requires storage and handling of corrosive chemicals. Special safety training will be required.
<b>ENVIRONMENTAL AND AESTHETIC CRITERIA</b>	
<b>1. Traffic:</b>	There will be an increase in traffic due to delivery of chemicals and removal of struvite.
<b>2. Noise:</b>	There will be no significant increase in noise.
<b>3. Visual:</b>	New, relatively tall structures will have to be constructed.
<b>4. Odours:</b>	Phosphorus release units will be handling in part primary sludge (from SEWPCC and NEWPCC) and therefore, odour control for this facility would have to be considered.
<b>COST CRITERIA</b>	
<b>1. Capital Cost:</b>	This alternative involves major capital investment. If the equipment was sized only for the interim period, i.e. before biological phosphorus removal is introduced at NEWPCC, it is expected the cost would be in excess of \$10 million.
<b>2. Operating and Maintenance Costs:</b>	Additional O&M costs are associated with the increase in chemical use and maintenance of the new mechanical equipment.



**Chemical Phosphorus  
Removal Using Ballasted  
Flocculation**

<b>ALTERNATIVE 4</b>	<b>CHEMICAL PHOSPHORUS REMOVAL USING BALLASTED FLOCCULATION</b>
<b>STANDARD:</b>	Maintain Secondary Clarifier Effluent TP to 2017/2018 Levels

**PROCESS DESCRIPTION**

The larger NEWPCC BNR Upgrade may include a ballasted flocculation process (i.e, Actiflo) for the treatment of wet weather flow. One option would be to construct this facility early and treat a portion of raw wastewater through this process to remove phosphorus to less than 1.5 mg/L. With an estimated 2023 flow of 192 ML/d, approximately 65% of the total flow (135 ML/d) would need to be directed through the ballasted flocculation system to achieve an overall final effluent TP of less than 1 mg/L. This option provides reduction of the final effluent concentration of the phosphorus but could increase the risk of scaling in the digesters, due to increased capture rate of phosphorus and nitrogen in the high rate clarification. Therefore, increased sidestream chemical dosing may also be needed. In this option approximately 7,300 kg/d of additional solids are generated as compared to the base case. This will result in the digester operating at capacity and increase risks associated with digester upsets.

Following the larger NEWPCC BNR Upgrade, this facility would then act as a wet weather treatment as originally intended.

A process flow schematic of the proposed upgrade of the NEWPCC is presented in **Figure 4**.

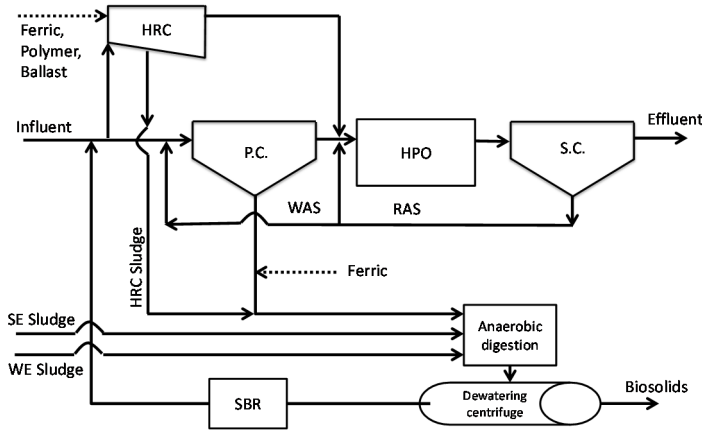

**Figure 4: Chemical Phosphorus Removal Using Ballasted Flocculation**

# Mass Balance 2023 Chemical Phosphorus Removal Using Ballasted Flocculation

0%

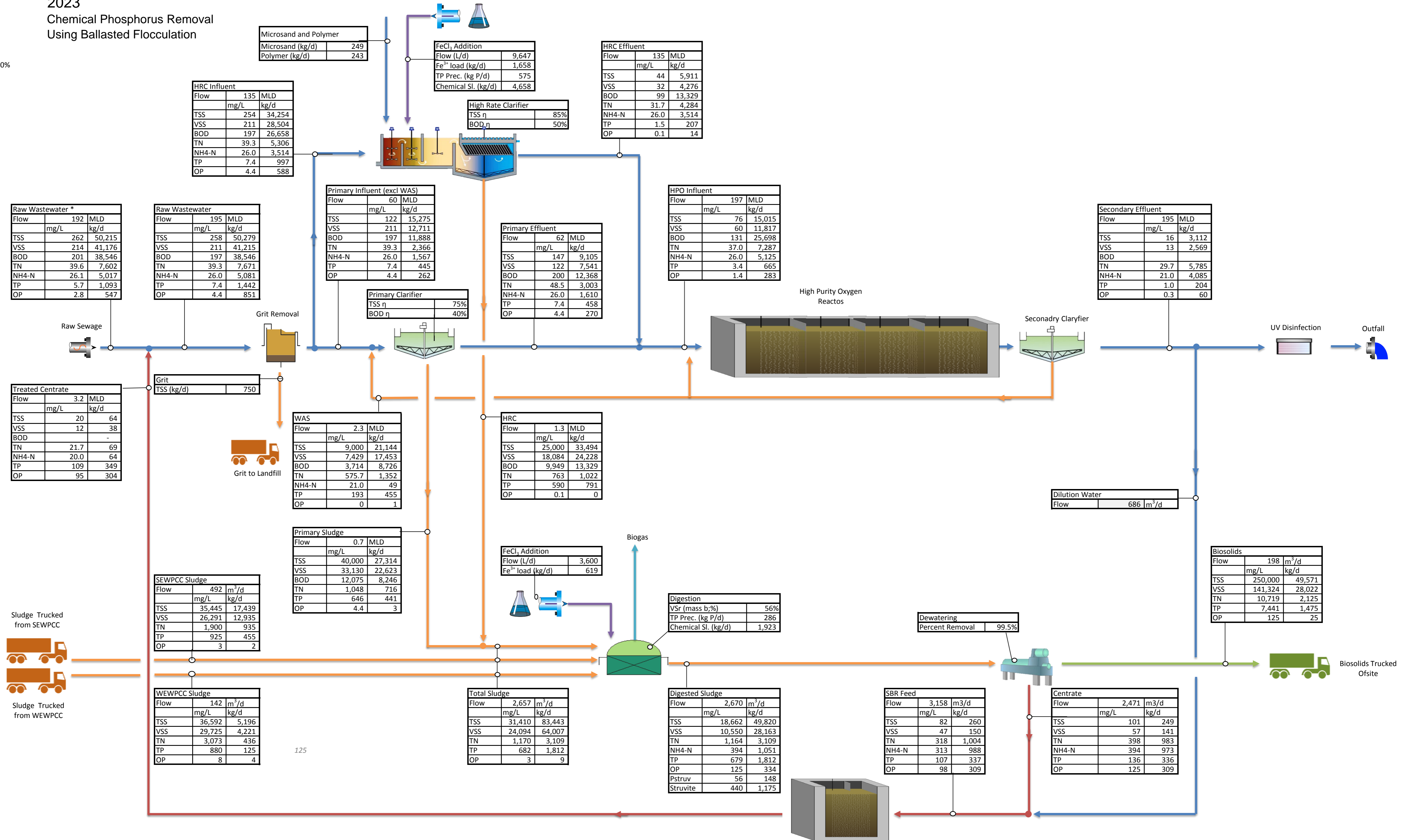

**NEWPCC – CHEMICAL PHOSPHORUS REMOVAL USING BALLASTED FLOCCULATION  
(Cont'd.)**

<b>PROCESS DESCRIPTION (Cont'd.)</b>	
<b>Main Features of Chemical Phosphorus Removal Using Ballasted Flocculation</b>	
<ul style="list-style-type: none"> <li>- Ballasted flocculation average flow 135 ML/d</li> <li>- Ballasted flocculation ferric dose 9.5 m<sup>3</sup>/d (1,600 kg Fe/d) and polymer dose 240 kg/d</li> <li>- Ferric dose to the digesters maintained at the current level of 3.6 m<sup>3</sup>/d (620 kg Fe/d)</li> <li>- Phosphorus concentration in the final effluent below 1 mg/L, load reduced by 600 kg/d (in comparison with the base case)</li> <li>- Increased solids load to the digesters 7,300 kg/d and capacity limitations</li> <li>- Significant risk of struvite scaling in digesters, dewatering and SBRs</li> </ul>	
<b>TECHNICAL CRITERIA</b>	
<b>1. Reliability:</b>	Ballasted flocculation is physical chemical process with a good record for treating raw wastewater. The process should be considered reliable. The polymer, metal salt and the ballast used in the process are relatively easily available. In this option however, digester capacity will be exceeded due to inert solids generation.
<b>2. Robustness:</b>	Mechanical equipment for this option such as chemical metering pumps and scraper mechanism are relatively robust.
<b>3. Flexibility:</b>	The operation staff will have the ability change the final effluent phosphorus concentration in two ways: (1) change the flow split ratio between the primary clarifiers and the Actiflo, and (2) adjust the dose of chemicals and ballast to the high rate clarifier in order to change the solids and phosphorus capture rate.
<b>4. Impact on Other Parts of the Plant:</b>	The increased capture rate of TSS and BOD in the high rate clarification will reduce the MLSS and oxygen demand in the HPO reactors. This means lower power demand for aeration and lower stress for the secondary clarifiers. However, the additional captured load of solids will increase the loading rate of the digesters. The high rate clarification will also increase the load of nitrogen and phosphorus fed to the digesters. As a result the potential for struvite generation in the digesters, SBR and dewatering almost triples from 440 kg/d to 1,175 kg/d (as dry struvite) in comparison to the base case option. The increased load of nitrogen in the sidestream may require the utilization of full SBR capacity, i.e. operation of both SBRs in continuous flow mode. The lower concentration of the sludge in high rate clarifiers will also reduce the SRT in the digesters, and may require pre-thickening. Biosolids production will also increase by about 17% from the base case.
<b>5. Space Requirements:</b>	The ballasted flocculation facility will require approximately 850 m <sup>2</sup> .

**NEWPCC – CHEMICAL PHOSPHORUS REMOVAL USING BALLASTED FLOCCULATION  
(Cont'd.)**

<b>6. Compatibility with Future BNR:</b>	High rate clarifiers are part of the plan of the future plant upgrade and could be reused for its intended purpose, i.e. wet weather treatment.
<b>7. Constructability:</b>	This alternative requires concrete tanks and a building to house auxiliary equipment and chemical storage.
<b>OPERATIONAL CRITERIA</b>	
<b>1. Ease of Operation:</b>	The process is designed for fully automatic start-up and operation during the wet weather events. Thus it should not require constant attention of operators. Regular monitoring of mechanical equipment and chemical storage will be required.
<b>2. Ease of Maintenance:</b>	The maintenance activities will be similar to those currently conducted in primary clarifiers, ferric dosing and polymer make-up facilities.
<b>3. Operator Safety:</b>	Plant staff is already using ferric chloride and polymer both in dry and liquid form, and therefore, are aware of the inherent risks associated with its handling.
<b>ENVIRONMENTAL AND AESTHETIC CRITERIA</b>	
<b>1. Traffic:</b>	There would be additional deliveries for the delivery of chemicals and increase in the traffic (17%) for biosolids disposal.
<b>2. Noise:</b>	There will be no significant increase in noise.
<b>3. Visual:</b>	New building will be constructed in headworks area.
<b>4. Odours:</b>	High rate clarifiers will be treating raw sewage and therefore odour control for this facility should be considered
<b>COST CRITERIA</b>	
<b>1. Capital Cost:</b>	Based on the estimates prepared for the future BNR plant upgrade the capital cost would be in excess of \$10 million.
<b>2. Operating and Maintenance Costs:</b>	Additional O&M costs are associated with the increase in chemical use and sludge processing.





**Chemically Enhanced  
Primary Treatment**

<b>ALTERNATIVE 5</b>	<b>CHEMICALLY ENHANCED PRIMARY TREATMENT</b>
<b>STANDARD:</b>	Effluent TP 1 mg/L – 30 Day Rolling Average

**PROCESS DESCRIPTION**

This option entails the addition of aluminum or ferric salts, sometimes with a polymer, to increase TSS, BOD, and TP removals in primary treatment. Metal salts precipitate phosphorus and would have to be monitored to ensure that phosphorus concentrations are not reduced to the point that it is not available for biological metabolism in secondary treatment. This can create conditions that promote the growth of filamentous organisms. The use of ferric chloride may also impact ultraviolet (UV) disinfection. Generally, dissolved iron concentrations less than 0.3 mg/L and total iron less than 1.0 mg/L do not pose a concern. For NEWPCC excess ferric would typically precipitate in the aeration basin and be removed in the secondary clarifiers.

Based on the mass balance, approximately 12 m<sup>3</sup>/d of ferric chloride (or other metal salt) dosed to the primary clarifier would be needed to reduce the secondary effluent total phosphorus to below 1 mg/L. Approximately 5,600 kg/d of additional solids will be generated which will likely exceed the capacity of the digesters at certain times of the year (i.e., SRT < 15 days).

A process flow schematic of the proposed upgrade of the NEWPCC to CEPT is presented in **Figure 5**.

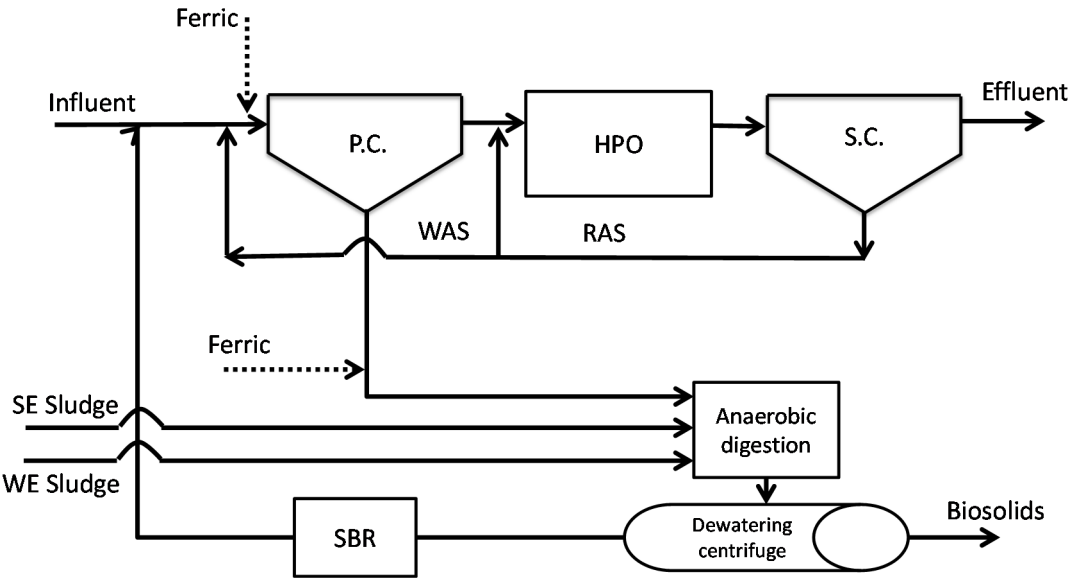

**Figure 5: Chemically Enhanced Primary Treatment at the NEWPCC**

# Mass Balance 2023 Chemically Enhanced Primary Treatment

1%

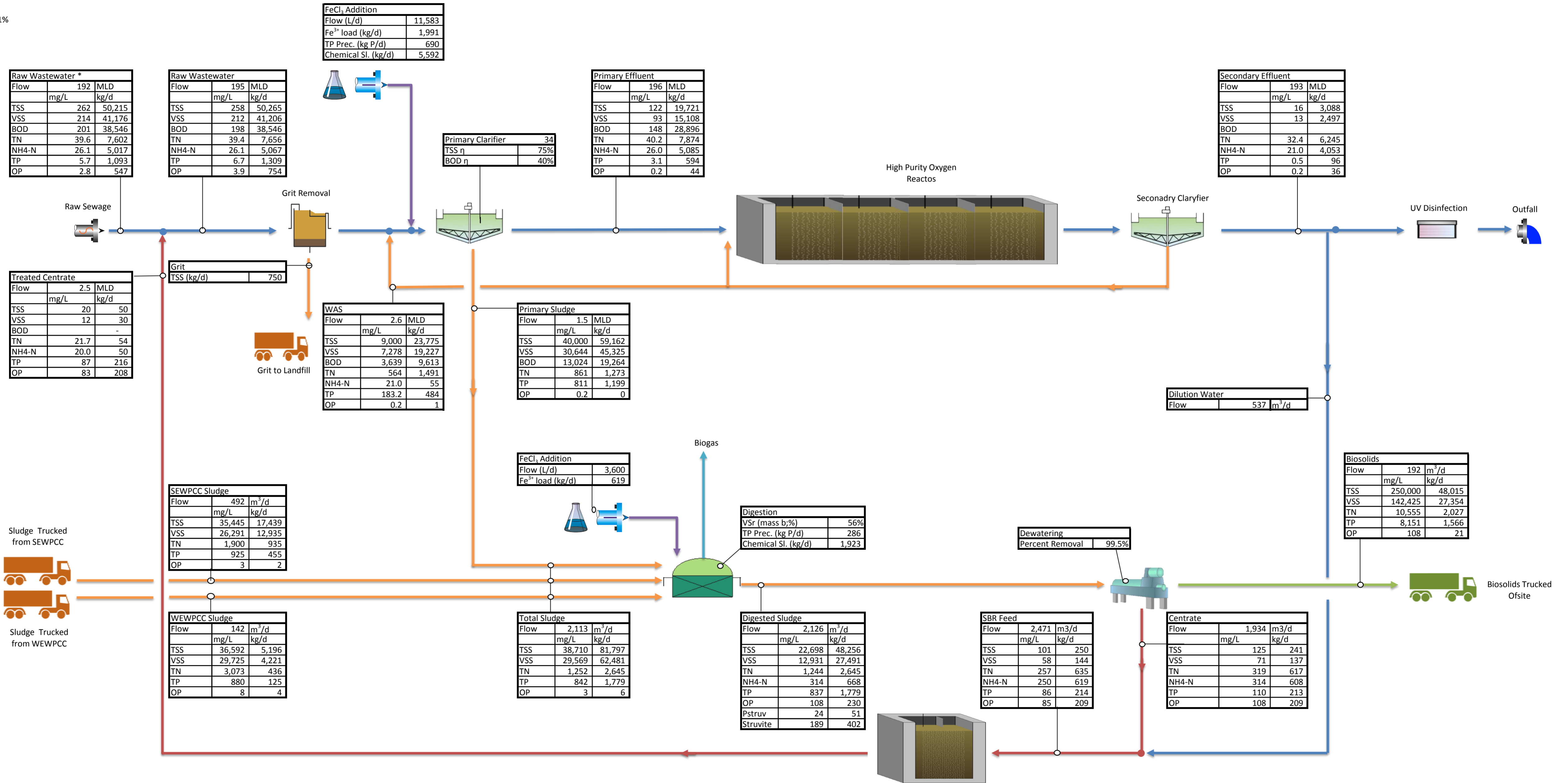

## NEWPCC – Chemically Enhanced Primary Treatment (Cont'd.)

<b>PROCESS DESCRIPTION (Cont'd.)</b>	
<p><b>Main Features of Chemically Enhanced Primary Treatment</b></p> <ul style="list-style-type: none"> <li>- Ferric dose to the Primary Influent at 11.6 m<sup>3</sup>/d (2,000 kg Fe/d)</li> <li>- Ferric dose to the digesters maintained at the current level of 3.6 m<sup>3</sup>/d (620 kg Fe/d)</li> <li>- Phosphorus concentration in the final effluent below 1 mg/L, load reduced by 700 kg/d (in comparison with the base case)</li> <li>- Increased inert solids loading to the primary clarifier by 5,600 kg/d or 7.5%(in comparison with the base case)</li> <li>- Increase in solids load by 5,700 kg/d (exceeding capacity of digesters, i.e., SRT &lt; 15 days)</li> <li>- Significant risk of struvite scaling in digesters, dewatering and SBRs</li> </ul>	
<b>TECHNICAL CRITERIA</b>	
<b>1. Reliability:</b>	The reliability of the process is largely dependent on providing adequate dose and dispersion of the metal salts upstream of the primary clarifiers. Since the primary purpose of CEPT is phosphorus trimming and not BOD/TSS removal, precise control is not required. If this alternative is selected metal salts could also be dosed into the HPO tanks for polishing. One of the critical factors will be delivery of chemicals. Currently the NEWPCC has 2 x 70 m <sup>3</sup> storage tanks. This would provide approximately ten days of storage at the proposed dose rate. In this option however, digester capacity will be exceeded due to inert solids generation.
<b>2. Robustness:</b>	This alternative requires relatively accurate dosing of chemicals upstream of the primary clarifiers. Equipment such as chemical metering pumps and chemical storage are considered relatively robust.
<b>3. Flexibility:</b>	Since operations staff will have the ability to change the chemical dose based on desired effluent quality this process is considered flexible.
<b>4. Impact on Other Parts of the Plant:</b>	The addition of chemicals for CEPT will increase the overall sludge quantities in the primary clarifiers, and could potentially have an impact on the sludge collection system. Overall, sludge production will increase by about 15 percent. This is not expected to exceed the capacity of the existing digesters, but consideration should be given to the reduced digester capacity. Costs associated with additional trucking will need to be considered.
<b>5. Space Requirements:</b>	If the existing chemical storage tanks are used, this alternative will require minimal additional space requirements.
<b>6. Compatibility with Future BNR:</b>	The future BNR upgrade will likely have a back-up chemical phosphorus removal system, so this alternative could be incorporated into the future build-out.
<b>7. Constructability:</b>	This alternative requires minimal construction.

## NEWPCC – Chemically Enhanced Primary Treatment (Cont'd.)

<b>OPERATIONAL CRITERIA</b>	
<b>1. Ease of Operation:</b>	Positive displacement chemical dosing pumps are already used at the NEWPCC to feed ferric chloride to the digestion/dewatering process. The addition of pumps for CEPT would be automated, and would require period attention and monitoring by staff.
<b>2. Ease of Maintenance:</b>	Maintenance would be relatively straightforward and typical of equipment maintenance requirements.
<b>3. Operator Safety:</b>	Although plant staff is already using ferric chloride, because of its nature special training should be given to minimize the risk of an incident and to properly deal with an incident should one occur.
<b>ENVIRONMENTAL AND AESTHETIC CRITERIA</b>	
<b>1. Traffic:</b>	There would be additional deliveries for the delivery of metal salts and biosolids disposal.
<b>2. Noise:</b>	There will be no increase in noise.
<b>3. Visual:</b>	There will be no visual changes.
<b>4. Odours:</b>	If ferric chloride is used, it is expected that odours would be reduced. If an alternative metal salt is used, there would be no noticeable difference in odour.
<b>COST CRITERIA</b>	
<b>1. Capital Cost:</b>	If the existing chemical storage system is used, there are very minor major capital cost items. Chemical pumps and dual contained piping are required.
<b>2. Operating and Maintenance Costs:</b>	Additional O&M costs are associated with the increase in chemical use and sludge processing.

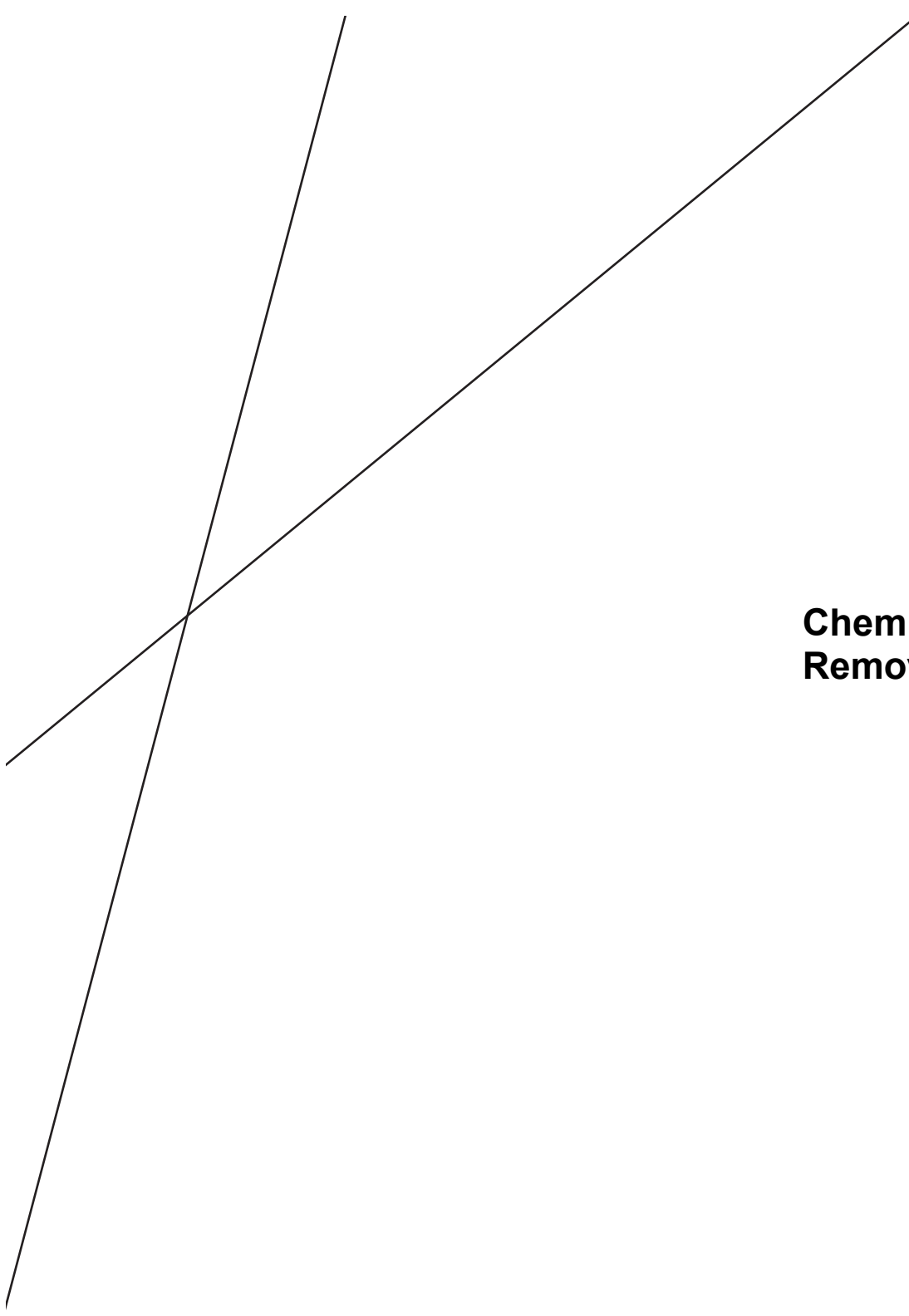

**Chemical Phosphorus  
Removal in HPO**

<b>ALTERNATIVE 6</b>	<b>CHEMICAL PHOSPHORUS REMOVAL IN HPO</b>
<b>STANDARD:</b>	Effluent TP 1 mg/L – 30 Day Rolling Average

**PROCESS DESCRIPTION**

This entails adding aluminum or ferric salts, to the HPO reactors or to the secondary clarifier influent, allowing the phosphorus to be precipitated within the mixed liquor. This option could be used in conjunction with CEPT, that is, removing a portion of the phosphorus in primary treatment, and polishing in the secondary process. Approximately 12 m<sup>3</sup>/d of ferric chloride (or alternative metals salt) would be needed to reduce the secondary effluent total phosphorus to less than 1 mg/L. Since the chemical is dosed to the secondary process, it will increase the mixed liquor concentration by about 500 mg/L. This in turn will increase the clarifier solids loading rate. In this option, nuisance struvite formation is expected in the dewatering process, so it is also recommended that the metal salt dose to the digesters be increased. In this option digester capacity will be exceeded due to additional solids generation of 5,600 kg/d (i.e., digester SRT < 15 days).

A process flow schematic of the proposed upgrade is presented in **Figure 6**.

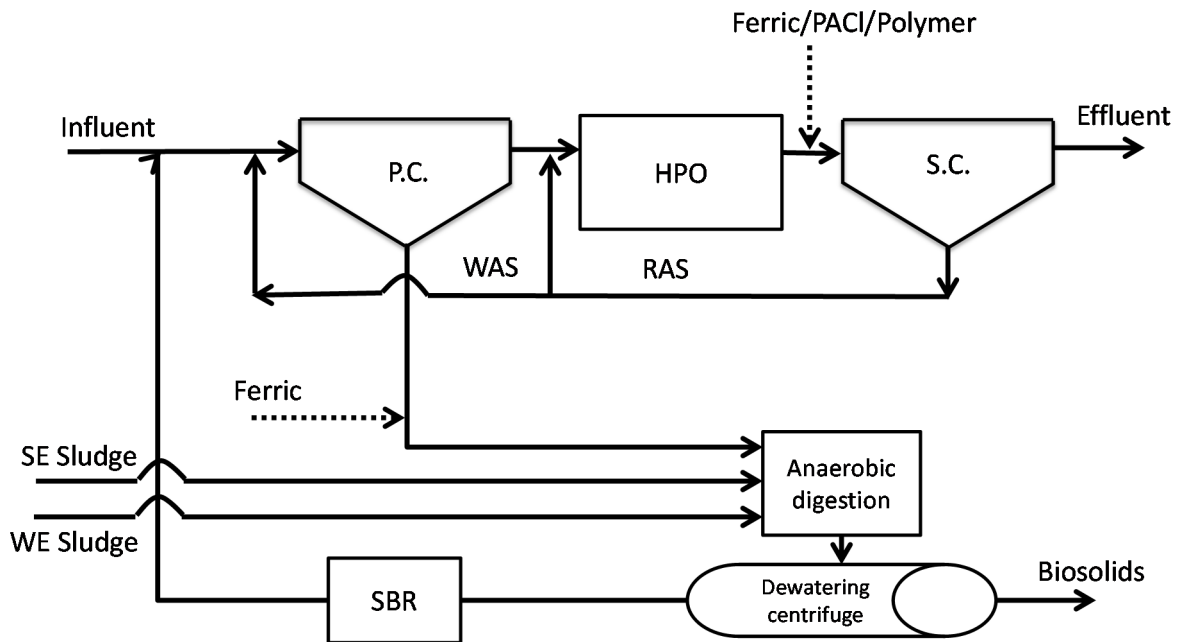

**Figure 6: Chemical Phosphorus Removal in HPO**

Mass Balance  
2023  
Chemical Phosphorus Removal in HPO

-1%

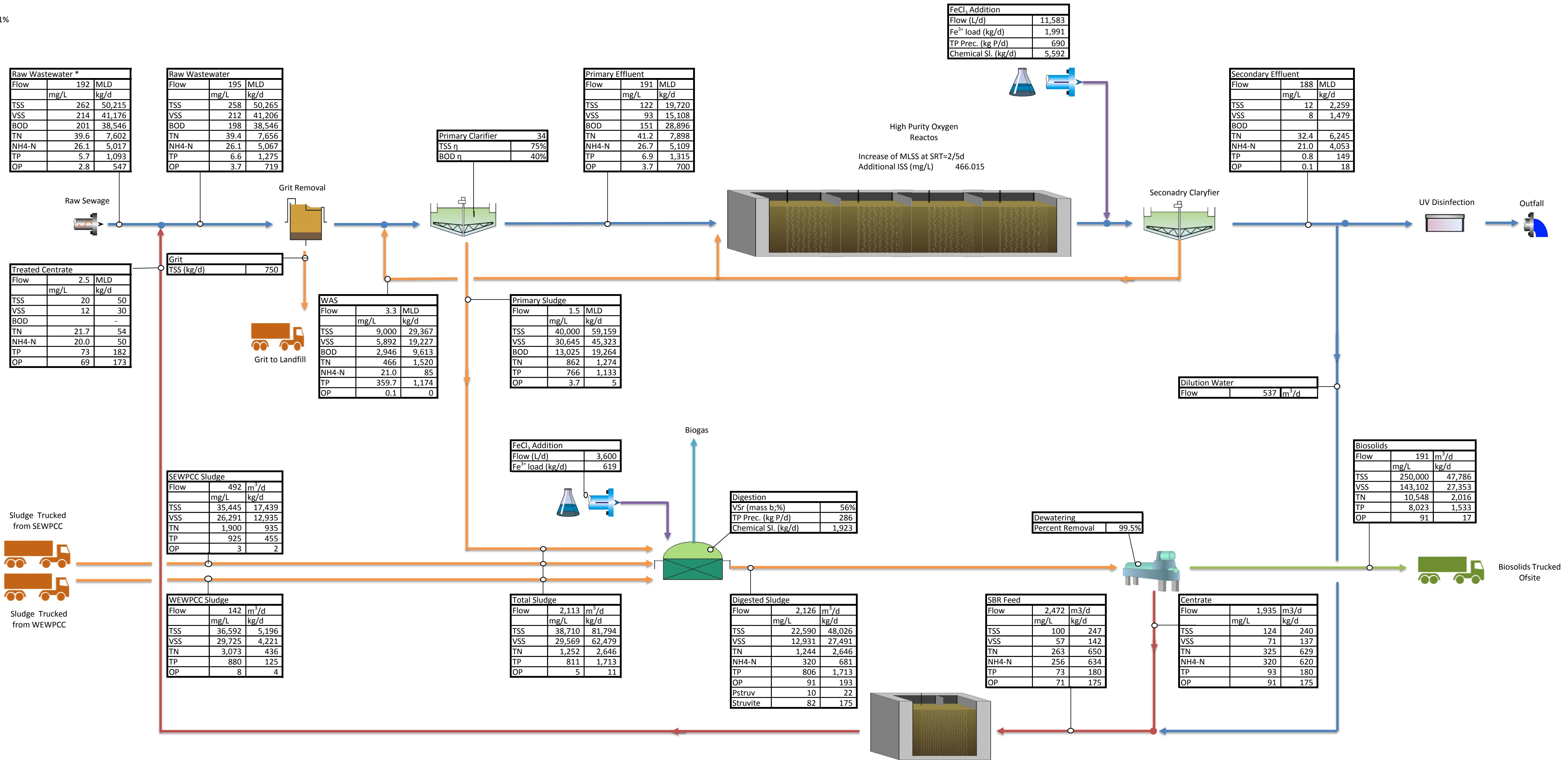



## NEWPCC – Chemical Phosphorus Removal in HPO (Cont'd.)

<b>PROCESS DESCRIPTION (Cont'd.)</b>	
<b>Main Features of Chemically Phosphorus Removal in HPO</b>	
<ul style="list-style-type: none"> <li>- Ferric dose to the Secondary Clarifiers at 11.6 m<sup>3</sup>/d (2,000 kg Fe/d)</li> <li>- Ferric dose to the digesters maintained at the current level of 3.6 m<sup>3</sup>/d (620 kg Fe/d)</li> <li>- Phosphorus concentration in the final effluent below 1 mg/L, load reduced by 650 kg/d (in comparison with the base case)</li> <li>- Increased MLSS in the HPO by 500 mg/L</li> <li>- Increased solids loading to the primary clarifier and digesters by 5,600 kg/d</li> <li>- Significant risk of struvite scaling in digesters, dewatering and SBRs</li> </ul>	
<b>TECHNICAL CRITERIA</b>	
<b>1. Reliability:</b>	The additional of metal salts to mixed liquor is a well established and reliable technology. The primary disadvantage is the increase in mixed liquor concentration (by 500 mg/L) and the ability of the secondary clarifiers to accommodate the increased loading rate. AECOM has had success with various types of metal salts, including polyaluminum chloride (PACl) in conjunction with polymers which can lead to reduced chemical use, and improved settling. However, in this scenario due to the large amount of inert solids, the digester capacity will likely be exceeded.
<b>2. Robustness:</b>	This alternative is considered robust and does not require any unusual equipment for operation.
<b>3. Flexibility:</b>	Since operations staff will have the ability to change chemical dosage based on desired effluent quality this process is considered flexible. If used in conjunction with CEPT, this alternative is considered very flexible.
<b>4. Impact on Other Parts of the Plant:</b>	The addition of chemicals to the HPO reactors will increase the overall sludge quantities generated at the NEWPCC. Overall, sludge production will increase by about 15 percent. This is not expected to exceed the capacity of the existing digesters, but consideration should be given to the reduced capacity when units are out of service.
<b>5. Space Requirements:</b>	If the existing chemical storage tanks are used, this alternative will require minimal additional space requirements. It is recommended that a polymer be considered to reduce overall chemical use and sludge production. If this is case space will be required for polymer tanks.
<b>6. Compatibility with Future BNR:</b>	The future BNR upgrade will incorporate a chemical back-up system and therefore, it is envisioned that this alternative could be incorporated into the future build-out.
<b>7. Constructability:</b>	This alternative requires minimal construction.
<b>OPERATIONAL CRITERIA</b>	
<b>1. Ease of Operation:</b>	Positive displacement chemical dosing pumps are already used at the NEWPCC and therefore, a similar type of operation is expected.

## NEWPCC – Chemical Phosphorus Removal in HPO (Cont'd.)

<b>2. Ease of Maintenance:</b>	Maintenance would be relatively straightforward and typical of equipment maintenance requirements.
<b>3. Operator Safety:</b>	Continued training should be given to minimize the risk of an incident and to properly deal with an incident should one occur.
<b>ENVIRONMENTAL AND AESTHETIC CRITERIA</b>	
<b>1. Traffic:</b>	There would be additional deliveries for the delivery of metal salts and an increase in the traffic (15%) for biosolids disposal.
<b>2. Noise:</b>	There will be no significant increase in noise.
<b>3. Visual:</b>	There will be no visual changes.
<b>4. Odours:</b>	There would be no noticeable difference in odour from the current levels.
<b>COST CRITERIA</b>	
<b>1. Capital Cost:</b>	Capital costs are considered minor. No new large equipment is envisioned.
<b>2. Operating and Maintenance Costs:</b>	Additional O&M costs are associated with the increase in chemical use and sludge processing



**Tertiary Phosphorus  
Removal Using Effluent  
Filtration**

<b>ALTERNATIVE 7</b>	<b>TERTIARY PHOSPHORUS REMOVAL USING EFFLUENT FILTRATION EFFLUENT</b>
<b>STANDARD:</b>	Effluent TP 1 mg/L – 30 Day Rolling Average

**PROCESS DESCRIPTION**

As an alternate to ballasted flocculation, the City is also considering the AquaPrime® cloth media filter for treating wet weather flows. If chosen, this filter would be configured to treat raw wastewater flow during wet weather events, or secondary effluent during normal flow periods. The filtration unit could be constructed ahead of schedule, and used to provide tertiary phosphorus removal on the secondary effluent. This would involve dosing approximately 15 m<sup>3</sup>/d of metal salt upstream of the filters to maintain an effluent TP less than 1 mg/L. This would generate about 6,300 kg/d of chemical sludge that would either be backwashed back to the primary clarifiers, or thickened separately and blended with the thickened sludge sent to the digesters. In this option digester capacity will be exceeded due to inert solids generation.

A process flow schematic of the proposed upgrade is presented in **Figure 7**.

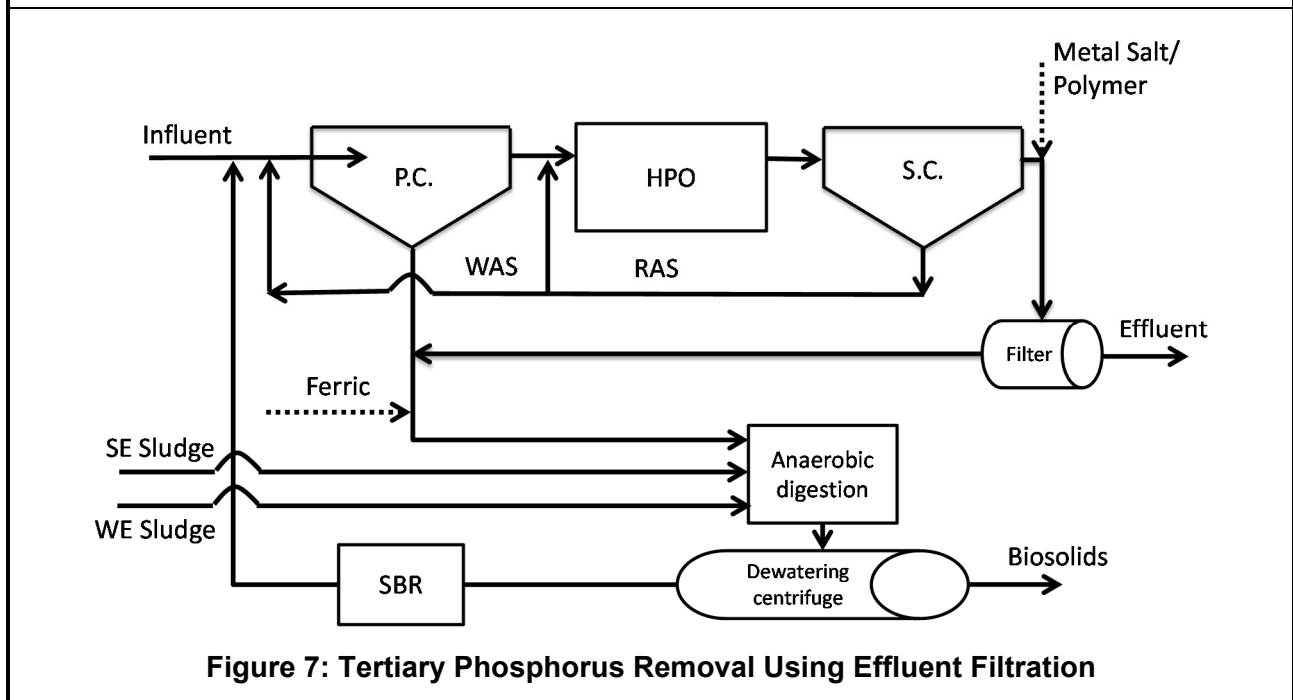

**Figure 7: Tertiary Phosphorus Removal Using Effluent Filtration**

# Mass Balance 2023 Tertiary Phosphorus Removal Using Effluent Filtration

0%

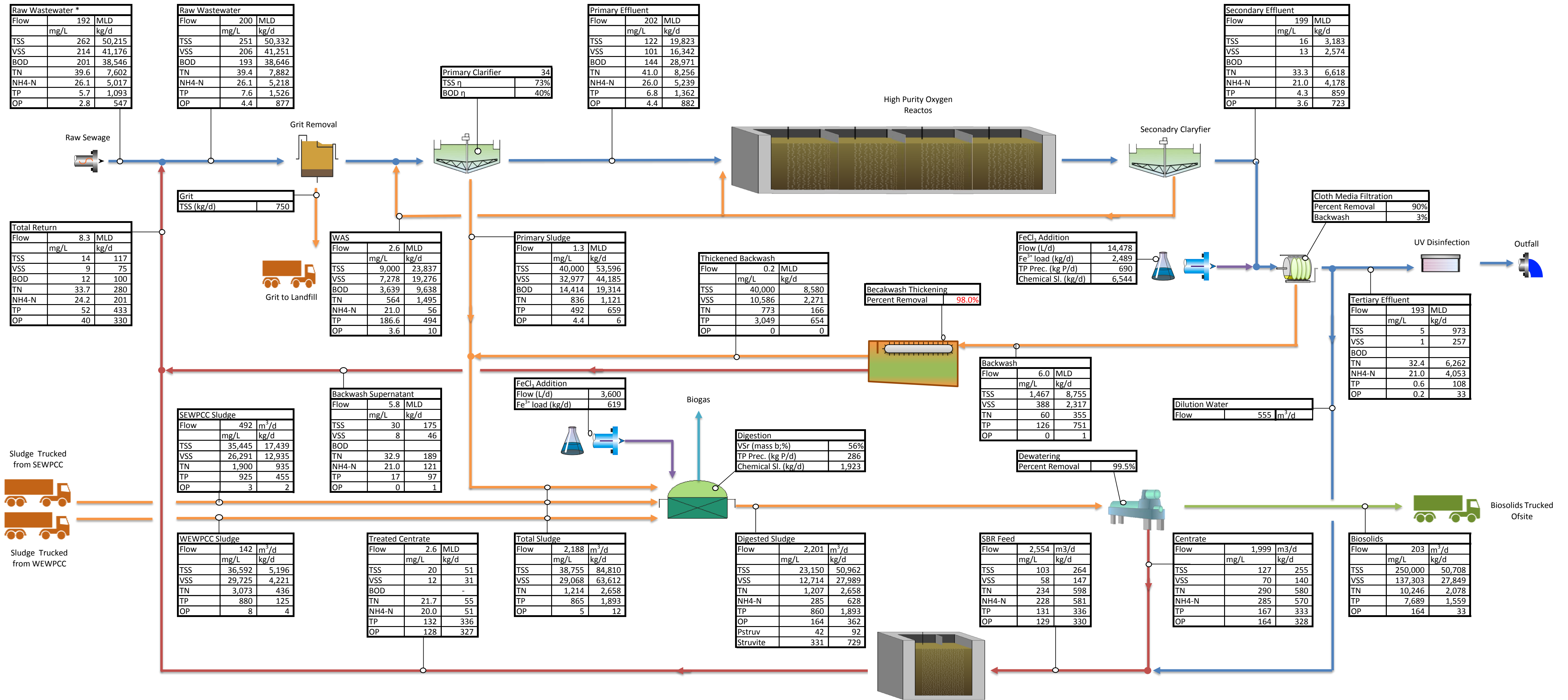

## NEWPCC – Tertiary Phosphorus Removal from Secondary Effluent (Cont'd.)

<b>PROCESS DESCRIPTION (Cont'd.)</b>	
<b>Main Features of Tertiary Phosphorus Removal Using Effluent Filtration</b>	
<ul style="list-style-type: none"> <li>- Ferric dose to the Secondary Effluent at 14.5 m<sup>3</sup>/d (2,500 kg Fe/d)</li> <li>- Ferric dose to the digesters maintained at the current level of 3.6 m<sup>3</sup>/d (620 kg Fe/d)</li> <li>- Phosphorus concentration in the final effluent below 1 mg/L, load reduced by 700 kg/d (in comparison with the base case)</li> <li>- Increased inert solids load to the digesters 6,300 kg/d</li> <li>- Significant risk of digester capacity being exceeded</li> <li>- Significant risk of struvite scaling in digesters, dewatering and SBRs</li> </ul>	
<b>TECHNICAL CRITERIA</b>	
<b>1. Reliability:</b>	Tertiary filtration coupled with chemical precipitation is provides consistent low effluent total phosphorus concentrations. There are multiple plants in North America producing effluent TP below 0.1 mg TP/L utilizing this approach. However, the issue for NEWPCC will be the impact on the digesters and their capacity being exceeded.
<b>2. Robustness:</b>	The chemical dosing equipment is relatively robust and spare parts are readily available. The AuqaPrime filtration process is designed to withstand the handling of raw sewage with minimum maintenance required. In a tertiary filtration application it should be considered robust.
<b>3. Flexibility:</b>	The filtration unit would be configured such that it would allow treatment of raw sewage bypass during high flow events providing better quality of final effluent at lower hydraulic stress of secondary clarifiers. The chemical dosing system could be easily coupled with other dosing points (e.g. to primary clarifier) allowing optimization of the overall chemical dose and sludge production. The system could be also used with other metal salts, i.e. polyaluminum chloride or ferrous chloride.
<b>4. Impact on Other Parts of the Plant:</b>	The precipitation of phosphorus to low effluent soluble phosphorus concentrations generally requires a higher metal salt dose. That is, the dose per kilogram of phosphorus removal will be higher in a tertiary treatment application than in a primary clarifier application. The additional chemical sludge generated will increase solids loading rate to the digesters and also to the primary clarifiers if the backwash is not thickened separately. The biosolids production will increase by 21% in comparison with base case. The relatively high backwash flowrate between 3% and 6% (continuous) will increase surface overflow rate in secondary clarifiers. This option, although producing low final effluent phosphorus concentration does not address potential scaling in the digesters.
<b>5. Space Requirements:</b>	Since this alternative will still require the same or higher doses of ferric to the digesters, the existing storage facility would provide only eight days of storage. Thus, it is expected this option would require new chemical storage. Estimated total required space would be 650 m <sup>2</sup> .

## NEWPCC – Tertiary Phosphorus Removal from Secondary Effluent (Cont'd.)

<b>6. Compatibility with Future BNR:</b>	The cloth media filters are already considered as an alternative for the wet weather treatment for the BNR upgrade, so if built early it could be utilized in the future. The future BNR upgrade will incorporate a chemical back-up system and therefore, the new ferric storage could be incorporated into the future build-out.
<b>7. Constructability:</b>	This alternative requires construction of concrete tankage and chemical storage building.
<b>OPERATIONAL CRITERIA</b>	
<b>1. Ease of Operation:</b>	The cloth media filters proposed as the alternative to high rate clarifiers for the BNR upgrade are continuous and automatic backwash units. Operational involvement for the most part will be limited to monitoring of head loss trends and periodical visual inspection of equipment.
<b>2. Ease of Maintenance:</b>	Maintenance would be relatively straightforward and typical of equipment maintenance requirements.
<b>3. Operator Safety:</b>	Continued training should be given to minimize the risk of an incident and to properly deal with an incident should one occur.
<b>ENVIRONMENTAL AND AESTHETIC CRITERIA</b>	
<b>1. Traffic:</b>	There would be additional deliveries for the delivery of metal salts and an increase in the traffic (21%) for biosolids disposal.
<b>2. Noise:</b>	There will be no significant increase in noise.
<b>3. Visual:</b>	New structure built in the headworks area.
<b>4. Odours:</b>	There would be no noticeable difference in odour from the current levels.
<b>COST CRITERIA</b>	
<b>1. Capital Cost:</b>	The capital cost will be in excess of \$10 million.
<b>2. Operating and Maintenance Costs:</b>	Additional O&M costs are associated with the increase in chemical use and sludge processing.

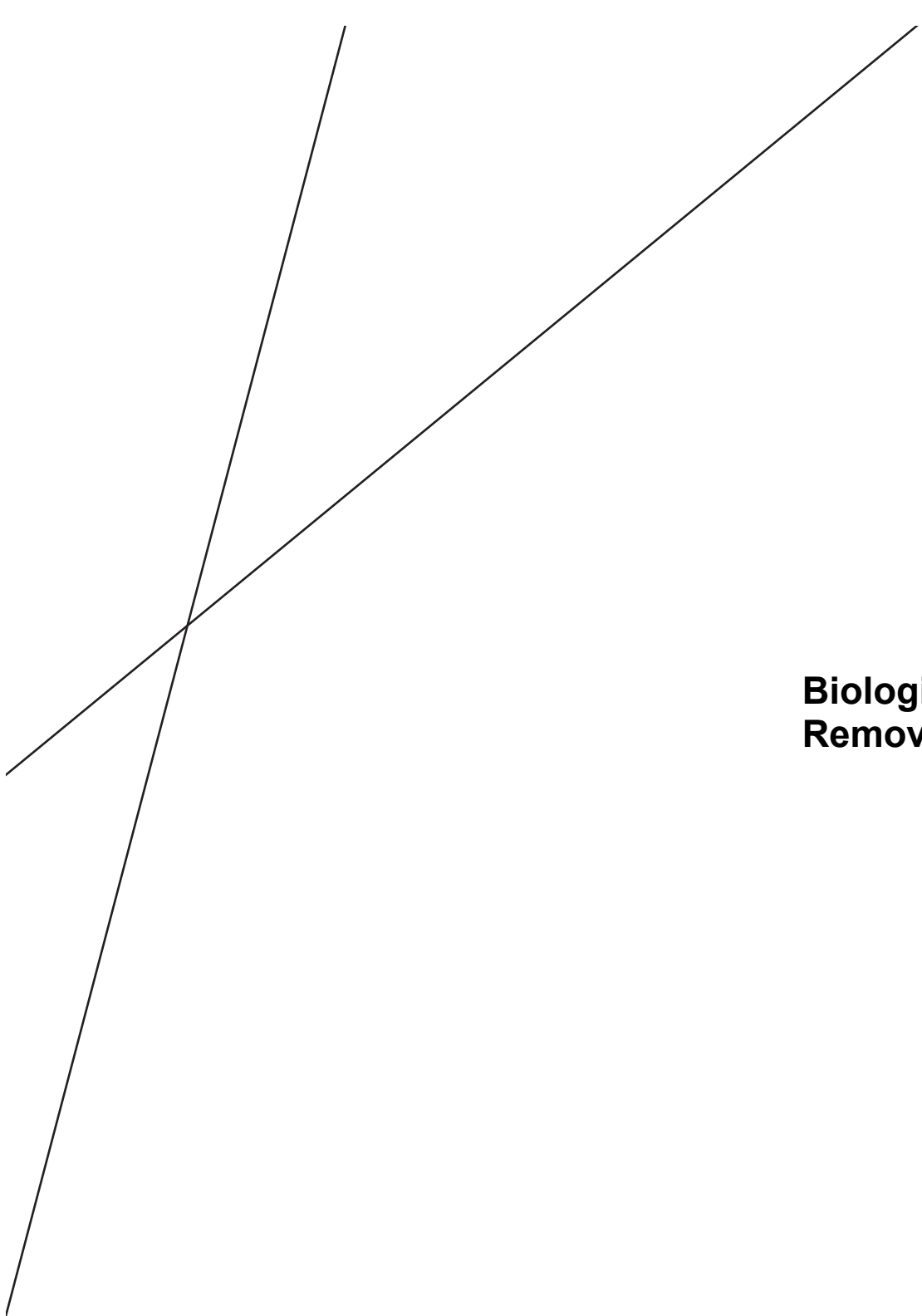

## **Biological Phosphorus Removal in HPO**



<b>ALTERNATIVE 8</b>	<b>BIOLOGICAL PHOSPHORUS REMOVAL IN HPO</b>
<b>STANDARD:</b>	Effluent TP 1 mg/L – 30 Day Rolling Average

**PROCESS DESCRIPTION**

In this option, an anaerobic reactor would be constructed to accept RAS from the secondary clarifiers. When this anaerobic zone is placed upstream of the HPO reactors, conditions exist for biological phosphorus removal. To prevent the re-release of phosphorus, co-thickening of WAS will need to be discontinued and a separate WAS thickening system constructed. Since all phosphorus is taken up biologically, it will also be released during anaerobic digestion. To break the phosphorus loop, approximately 12 m<sup>3</sup>/d of ferric chloride will need to be added to the digesters/dewatering. This may trigger the need for pH adjustment to the digesters.

A process flow schematic of the proposed upgrade of the NEWPCC is presented in **Figure 8**.

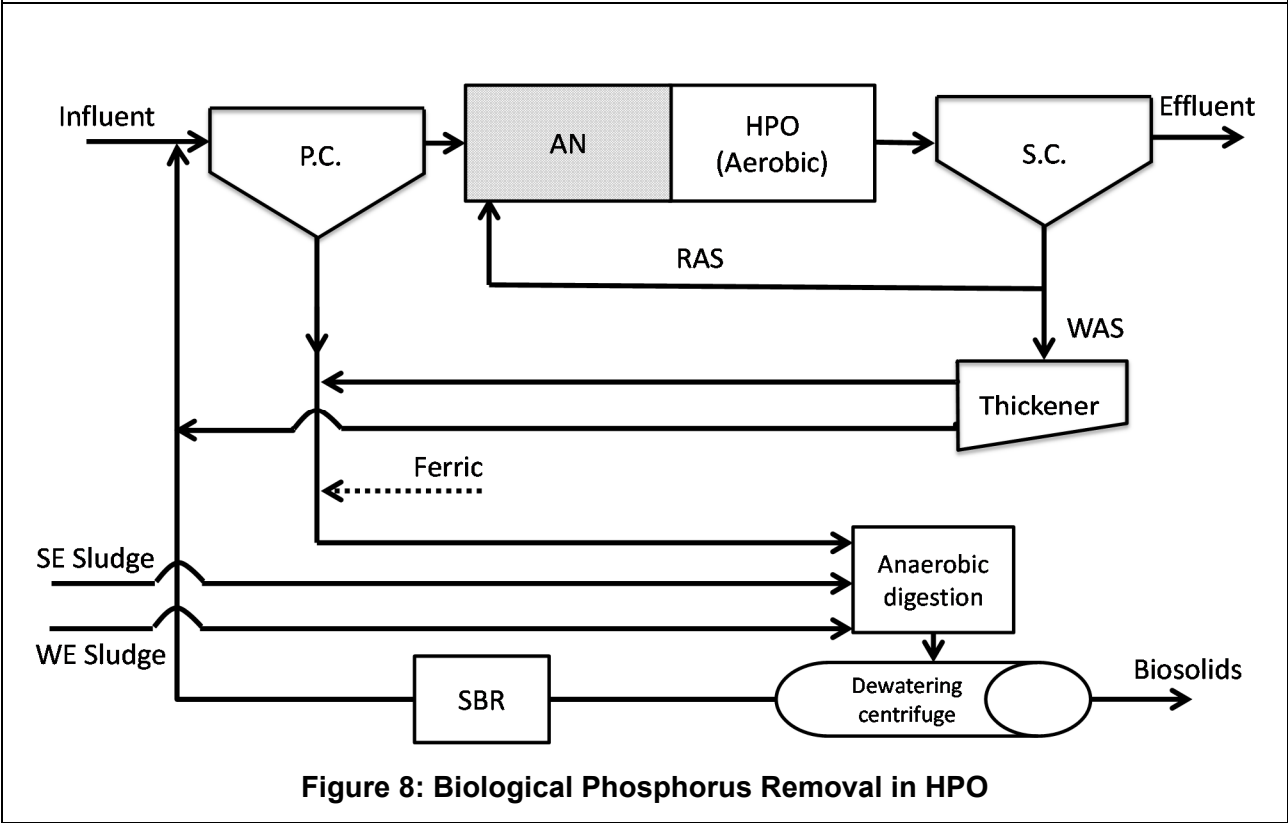

**Figure 8: Biological Phosphorus Removal in HPO**

# Mass Balance 2023 Biological Phosphorus Removal in HPO

2%

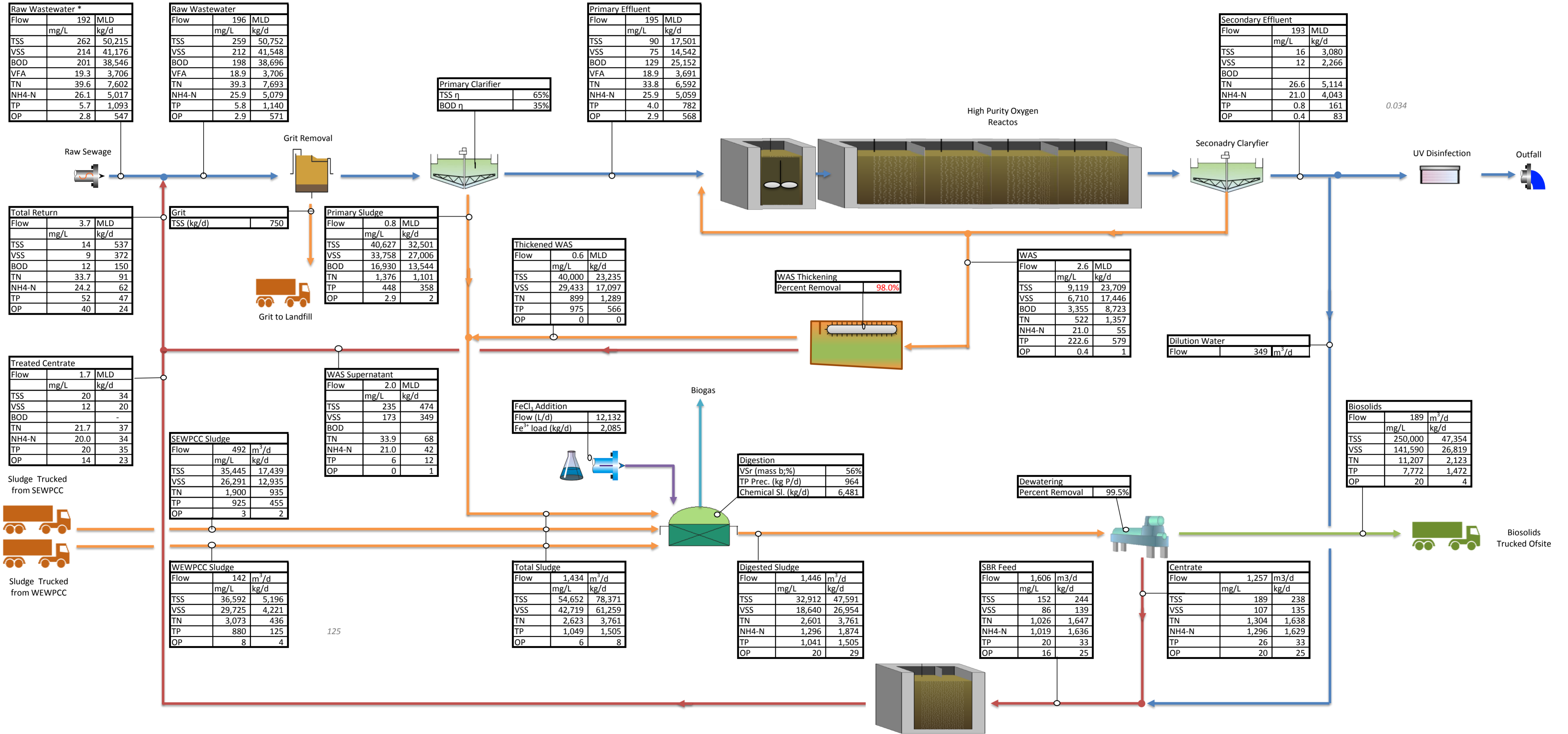

## NEWPCC – BIOLOGICAL PHOSPHORUS REMOVAL IN HPO (Cont'd.)

<b>PROCESS DESCRIPTION (Cont'd.)</b>	
<p><b>Main Features of Biological Phosphorus Removal in HPO</b></p> <ul style="list-style-type: none"> <li>- Anaerobic tank volume 5600 m<sup>3</sup></li> <li>- DAF for Separate WAS Thickening</li> <li>- Increased ferric dose to the digester feed 12 m<sup>3</sup>/d (2100 kg Fe/d)</li> <li>- Phosphorus concentration in the final effluent below 1 mg/L, load reduced by 530 kg/d (in comparison with the base case)</li> <li>- Increase in chemical sludge production by 4,500 kg/d</li> <li>- Increase biosolids production by 5,500 kg/d</li> <li>- Minimized risk of scaling in the digesters and downstream processes</li> </ul>	
<b>TECHNICAL CRITERIA</b>	
<b>1. Reliability:</b>	<p>Addition of the anaerobic zone also referred to as selector zone, would essentially convert the existing secondary process in to A/O process which is the first engineered process developed for the enhanced biological phosphorus removal (EBPR). Since first implementation in mid 1970s it has been used around the world under various influent and climate conditions providing relatively consistent effluents under 1 mg TP/L. The incorporation of the selector zone is also known to improve sludge settleability.</p>
<b>2. Robustness:</b>	<p>Critical to effective operation of the A/O process is to inhibit nitrification in the aerobic zone. The nitrates and nitrites produced in nitrification process are returned to anaerobic with RAS. This results in lower phosphorus removal rate. This requires relatively precise control of aerobic SRT especially in the summer.</p>
<b>3. Flexibility:</b>	<p>Flexibility of this system is limited.</p>
<b>4. Impact on Other Parts of the Plant:</b>	<p>The new anaerobic zone would improve sludge settleability and reduce risk of filamentous sludge bulking, thus reducing the stress on secondary clarifiers. Waste secondary sludge (WAS) produced in A/O system would need to be thickened separately from primary sludge, which will require construction of a separate thickening system. The additional load of phosphorus captured in the A/O process will be almost completely released in the digestion process creating risk of rapid scaling buildup in the digesters and downstream processes. This could be mitigated by increasing the dose of ferric chloride to the digester sludge feed to about 12 m<sup>3</sup>/d. The high ferric dose will result in increased biosolids production, 13% from the base case.</p> <p>The anaerobic zone will have to fit on the hydraulic profile in a narrow space between the existing HPO feed channels and HPO tanks. Detail investigation would be required but likely existing RAS pumps would have to be upgraded and possibly intermediate primary effluent pumping may be required.</p>

## NEWPCC – BIOLOGICAL PHOSPHORUS REMOVAL IN HPO (Cont'd.)

<b>5. Space Requirements:</b>	In this scenario existing ferric storage would provide 10 to 12 days of storage. Assuming no additional ferric tankage and primary effluent, the estimated space required for the anaerobic zone would be 220 m <sup>2</sup> at the proposed dose rate.
<b>6. Compatibility with Future BNR:</b>	If an intermediate primary effluent station was built with this upgrade allowing higher elevation of the anaerobic zone, it would be possible in the future to reuse the new tankage for a common anaerobic zone for new BNR system.
<b>7. Constructability:</b>	Due to limitations in hydraulic profile and limited access to the PE channels in HPO area the tie-in of the new anaerobic zone may be difficult.
<b>OPERATIONAL CRITERIA</b>	
<b>1. Ease of Operation:</b>	The A/O is a biological process, thus it will require a regular monitoring and periodical adjustments by operators. However, this is a simplified version of biological treatment used at WEWPCC and knowledge generated at that plant would be applicable.
<b>2. Ease of Maintenance:</b>	Maintenance will be relatively straightforward and similar existing equipment maintenance requirements.
<b>3. Operator Safety:</b>	Continued training should be given to minimize the risk of an incident and to properly deal with an incident should one occur.
<b>ENVIRONMENTAL AND AESTHETIC CRITERIA</b>	
<b>1. Traffic:</b>	There would be additional deliveries for the delivery of metal salts and an increase in the traffic (13%) for biosolids disposal.
<b>2. Noise:</b>	There will be no significant increase in noise.
<b>3. Visual:</b>	New structure built in the HPO area.
<b>4. Odours:</b>	There is a risk of slightly increased odour from the anaerobic portion of the reactor. In some plants built in tight urban areas anaerobic tanks are covered.
<b>COST CRITERIA</b>	
<b>1. Capital Cost:</b>	The capital cost will be in excess of \$10 million.
<b>2. Operating and Maintenance Costs:</b>	Additional O&M costs are associated with the increase in chemical use and sludge processing.

## Appendix 2 Future Activities to Achieve 1 mg/L phosphorous compliance

