



# Clearly Family Beverage Company

## Environment Act Proposal for the Clearly Canadian Beverage Wastewater Treatment System

Prepared by:

[Redacted]  
Oswald Wohlgemut, M.Sc.  
Environmental Scientist

[Redacted]  
Jef Dyck, P.Eng.  
Senior Municipal Engineer

March 2026

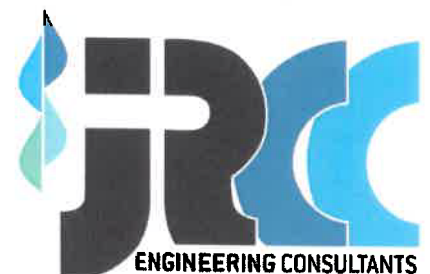
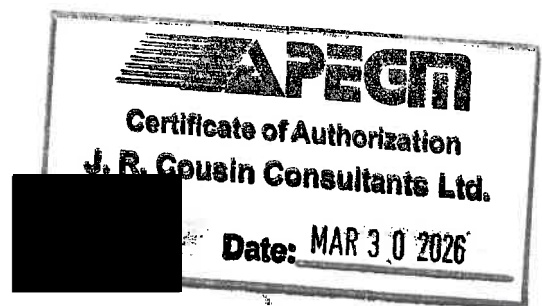
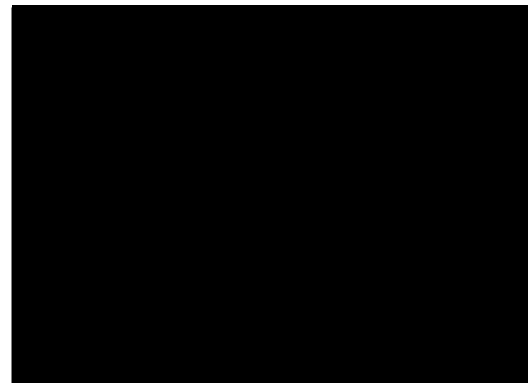

## **ACKNOWLEDGMENTS**

To prepare this report various sources of information were investigated and researched. JR Cousin Consultants Ltd. (JRCC) wishes to thank the Clearly Family Beverage Company who contributed to the data and content of this study. In addition, we wish to commend the Clearly Family Beverage Company for their fortitude in addressing the need for the long-term sustainable operation of a wastewater treatment lagoon which services the bottling plant and minimizes impacts to the surrounding environment.

## **REMARKS**

JR Cousin Consultants Ltd. has conducted this Environment Act Proposal in accordance with generally accepted professional engineering principles and practices for the purpose of identifying conditions that may have an environmental impact on the site. The findings and recommendations reached in this report are based on information made available to JRCC during the investigation and conditions at the time of the site investigation. Conclusions derived in this report are intended to reduce, but not wholly eliminate the uncertainty regarding potential environmental concerns on the site, and recognizes reasonable limitations with regards to time, accuracy, work scope and cost. It is possible that environmental conditions may change from the date of this report. If conditions appear different from those encountered and expressed in this report, JRCC should be informed so that mitigation recommendations can be reviewed and adjusted as required. Historical data and information obtained from personal communication used in this report, are assumed to be correct, however JRCC has not conducted further investigations into the accuracy of this data. JRCC has produced this report for the use of the client, and takes no responsibility for any third party decisions or actions based on information contained in this report.

## TABLE OF CONTENTS

| Section  | Page of Section |
|--|-----------------|
| <b>ENVIRONMENT ACT PROPOSAL FORM</b> .....                               | <b>i</b>        |
| <b>EXECUTIVE SUMMARY</b> .....   | <b>1</b>        |
| <b>1.0 INTRODUCTION AND BACKGROUND</b> .....                             | <b>1</b>        |
| 1.1 Introduction.....  | 1               |
| 1.2 Contact Information.....   | 1               |
| 1.3 Background Information.....  | 1               |
| 1.4 Description of Previous Studies.....                                 | 2               |
| 1.5 Project Description.....   | 2               |
| <b>2.0 DESCRIPTION OF THE DEVELOPMENT</b> .....                          | <b>1</b>        |
| 2.1 Land Title/Location.....   | 1               |
| 2.2 Owner of Land and Mineral Rights.....                                | 1               |
| 2.3 Existing Land Use.....   | 1               |
| 2.4 Land Use Designation/Zoning Designation.....                         | 1               |
| 2.5 Description of Development.....                                      | 2               |
| 2.5.1 Project Schedule.....  | 2               |
| 2.5.2 Review of System Site Location.....                                | 2               |
| 2.5.3 Land Classification.....   | 2               |
| 2.5.4 Effluent Discharge Route.....                                      | 2               |
| 2.5.5 Treatment System Access.....                                       | 3               |
| 2.6 Contributing Effluent.....   | 3               |
| 2.6.1 Wastewater Production.....   | 3               |
| 2.6.2 Raw Wastewater.....  | 4               |
| 2.7 Treatment System Design.....   | 5               |
| 2.8 Topography and Geotechnical Information.....                         | 5               |
| 2.8.1 Site Conditions and Topography.....                                | 6               |
| 2.8.2 Geotechnical Review.....   | 6               |
| 2.9 Review of Regulatory Requirements.....                               | 6               |
| 2.9.1 Effluent Quality Requirements.....                                 | 6               |
| 2.9.2 Nutrient Management Plan.....                                      | 6               |
| 2.10 Existing Storage Pond and Collection System.....                    | 7               |
| <b>3.0 POTENTIAL ENVIRONMENTAL IMPACTS AND MITIGATION MEASURES</b> ..... | <b>1</b>        |
| <b>4.0 RESIDUAL AND CUMULATIVE EFFECTS</b> .....                         | <b>1</b>        |
| <b>5.0 MONITORING AND FOLLOW-UP</b> .....                                | <b>1</b>        |
| <b>6.0 FUNDING AND APPROVALS</b> .....                                   | <b>1</b>        |
| <b>7.0 PUBLIC CONSULTATION</b> .....                                     | <b>1</b>        |
| <b>8.0 CONCLUSION</b> .....  | <b>1</b>        |

## **Appendix A**

Status of Title

Test Hole Log, JR Cousin Consultants Ltd., August 22, 2024

## **Appendix B**

Manitoba Historic Resources Branch, Memorandum, December 23, 2025

Manitoba Wildlife Branch, Data Centre Records, December 17, 2025

## **Appendix C**

Title Page

Plan 1: Site Location Plan

Plan 2: MBBR Layout Plan with Residential Setbacks and Drainage Route

Plan 3: Tank Layout Plan

Plan 4: UV Disinfection and Sampling Port Plan

# Environment Act Proposal Form

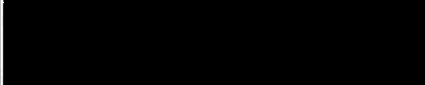

|  |  |
|--|--|
| Name of the development:<br>Clearly Family Beverage Company ULC - Wastewater Treatment System  |  |
| Type of development per Classes of Development Regulation (Manitoba Regulation 164/88):<br>Class 2 Development - Wastewater Treatment System |  |
| Legal name of the applicant:<br>Clearly Family Beverage Company ULC  |  |
| Mailing address of the applicant: 45137A, MB-210   |  |
| Contact Person: Alexandre Laraque  |  |
| City: Marchand   | Province: Manitoba      Postal Code: R0A 0Z0   |
| Phone Number: (204) 424-5358   | Fax:      email: alex.laraque@clearlyfab.com   |
| Location of the development: Clearly Family Beverage Company Property  |  |
| Contact Person: Alexandre Laraque  |  |
| Street Address: 45137A, MB-210   |  |
| Legal Description: SE 3-6-8 E1   |  |
| City/Town: Marchand  | Province: Manitoba      Postal Code: R0A 0Z0   |
| Phone Number: (204) 424-5358   | Fax:      email: alex.laraque@clearlyfab.com   |
| Name of proponent contact person for purposes of the environmental assessment:<br>Oswald Wohlgemut, M.Sc.                                    |  |
| Phone: (204) 489-0474  | Mailing address: JR Cousin Consultants Ltd.<br>91 A Scurfield Blvd.<br>Winnipeg, MB., R3Y 1G4  |
| Fax: (204) 489-0489  |  |
| Email address: owohlgemut@jrcc.ca  |  |
| Webpage address: www.jrcc.ca   |  |
| Date: 2026-03-05   | Signature of proponent, or corporate principal of corporate proponent:<br> |
|  | Printed name: Oswald Wohlgemut   |

PRINT

RESET

## EXECUTIVE SUMMARY

### General

The Clearly Family Beverage Company is proposing to install a new moving bed biofilm reactor (MBBR) wastewater treatment system on their property in Marchand, Manitoba. An Environment Act Licence will be required from Manitoba Environment and Climate Change (MECC) for the installation and operation of the wastewater treatment system. JR Cousin Consultants Ltd. (JRCC) was retained for the engineering services.

### Description

The new MBBR wastewater treatment system would be utilized for the treatment of wastewater from the water bottling plant. The MBBR system would service the process and domestic wastewater from the bottling plant operation.

### Contributing Wastewater

Based on information provided by the operations manager the estimated wastewater flows from the plant processing operations over the next several years will be a maximum of 20 m<sup>3</sup>/day. Additional flows of 1.7 m<sup>3</sup>/day would be estimated from the plant washrooms. The current flows are intermittent, based on the plant operating schedule, however the projected wastewater generation through 2028 and beyond, has been reviewed and incorporated into the design, including peak day loading. From a review of the historical raw wastewater effluent sampling, raw process wastewater strength was variable and included elevated CBOD results. The proposed treatment system has been designed to accommodate current operating conditions, projected future production, and appropriate peak loading factors. Nutrients, E coli and suspended solids concentrations in the raw wastewater were all lower than the provincial guidelines for treated effluent. Washroom wastewater will be connected into the treatment system to provide nutrients needed for bacterial growth.

### Wastewater Treatment System Design

The MBBR treatment system will consist of multiple tanks in series, which will act as clarifiers, sludge storage, MBBR biological treatment, phosphorus removal and pumping. The treatment system will also include UV disinfection in a control building with a PLC control unit and discharge piping to the existing wastewater storage pond.

### Effluent Quality

The owner will be required to meet the provincial effluent quality guidelines in the Environment Act Licence, along with the federal effluent quality regulation for coliforms, CBOD, TSS, residual chlorine, un-ionized ammonia and total phosphorus, in the operation of the system.

### Potential Concerns and Mitigation Measures

The potential concerns identified with the lagoon operation and associated mitigation measures include:

| Potential Concern  | Mitigation Measure   |
|--|--|
| Odour Nuisance   | The treatment system will be enclosed in a tank system. The existing pond will be pumped out, dredged of accumulated sludge, and utilized for storage of treated effluent, which is expected to minimize odour potential |
| Spills during Construction                                     | Spills clean up kits will be located onsite. The Manitoba Spills Action Centre will be contacted in the event of a chemical spill  |
| Health and Safety  | Perimeter fencing and a gate will be around the treatment system tanks and control building to prevent unauthorized entry.   |
| Contamination of Surface and Groundwater from System Operation | The MBBR system will treat the effluent to requirements of the Environment Act Licence prior to discharge into the storage pond  |

## Approvals

An Environment Act Licence is required from MECC for the installation and operation of the MBBR treatment system. The owner will be responsible to submit annual monitoring reports to Environment Canada and MECC (as required).

## 1.0 INTRODUCTION AND BACKGROUND

The proposal described in this document is for the development and operation of a wastewater treatment facility at the Clearly Family Beverage Company, in Marchand, Manitoba, in the RM of La Broquerie.

### 1.1 Introduction

The Clearly Family Beverage Company is proposing to construct a wastewater treatment facility on their property, in Marchand, Manitoba. The existing wastewater lagoon is currently operating without an Environment Act Licence. The new wastewater treatment facility would service the Clearly Canadian water bottling plant. An Environment Act Licence is required from Manitoba Environment and Climate Change (MECC) for the development and operation of a new wastewater treatment facility. JR Cousin Consultants Ltd. (JRCC) was retained for the related engineering services.

### 1.2 Contact Information

Jeff Dyck, P.Eng.  
JR Cousin Consultants Ltd.  
91A Scurfield Boulevard  
Winnipeg, Manitoba  
R3Y 1G4  
Phone: (204) 489-0474, Fax (204) 489-0487

Alexandre Laraque  
Clearly Family Beverage Company ULC  
45137A, MB-210  
Marchand, Manitoba  
ROA 0Z0  
Phone: (204) 424-5358

### 1.3 Background Information

The Clearly Canadian Beverage water bottling plant is located in the RM of La Broquerie, on the west side of Marchand, MB and is accessed by PR 210. The property is located at SE 3-6-8 E1. The bottling plant currently utilizes a gravity collection system from the plant to a buried collection tank on the north side of the building, which pumps the effluent to the one-cell wastewater storage pond.

The existing wastewater storage pond is located on the bottling facility property, and has been in operation since 1975, when the original bottling facility was constructed. The storage pond currently receives process wastewater from the bottling plant operations. The storage pond does not receive residential wastewater and does not have a spillway, access road or discharge pipe. The residential wastewater from the plant is directed to a septic system on the west side of the property. The Enforcement Officer for MECC had indicated in their inspection that there have been concerns with discharges from the unregulated pond from an overflow ditch into the nearby Seine River. The wastewater storage pond currently acts as an exfiltration pond with uncontrolled discharge into the

surrounding soils and into the discharge ditch to the east. The proposed development is intended to eliminate the current uncontrolled conditions by introducing mechanical treatment, controlled monitoring, sludge removal and regulated operation under an Environment Act Licence.

#### **1.4 Description of Previous Studies**

The report entitled *Phase I Environmental Site Assessment, Water Bottling Plant, Rural Municipality of La Broquerie, Manitoba*, by M P Wiebe Environmental Engineering (September 2009) was reviewed to obtain background information on the history of the property and site conditions present at the time of the inspection. The report indicated that the facility was constructed in 1975, with a building replacement in 1988, and the current ownership taking possession in 2007. The surrounding lands are historically residential, and there was no indication of significant environmental impacts from the site operations.

#### **1.5 Project Description**

The Clearly Family Beverage Company requires an Environment Act Licence for the development and operation of the new wastewater treatment facility. The new wastewater treatment facility will consist of a Moving Bed Biofilm Reactor provided by Waterloo Biofilter. The system will consist of nine buried tanks, with an above ground UV disinfection unit and PLC control, and a system discharge into the existing storage pond. The owner will monitor hydraulic loading to the treatment system and the discharge effluent quality regularly.

## 2.0 DESCRIPTION OF THE DEVELOPMENT

For each heading there is an information request from the Environment Act Proposal Form. These requests are repeated herein in italics followed by the pertaining response.

### 2.1 Land Title/Location

*Certificate of Title showing the owner(s) and legal description of the land upon which the development will be constructed; or, in the case of highways, rail lines, electrical transmission lines, or pipelines, a map or maps at a scale no less than 1:50,000 showing the location of the proposed development:*

The proposed wastewater treatment facility will be located at SE 3-6-8 E1, in the RM of La Broquerie. The location of the proposed facility layout is included on Plan 2 in Appendix C. The land parcel is currently owned by the Clearly Family Beverage Company ULC. A copy of the current Status of Title [No. 3201479/1] for the land on which the plant and proposed treatment system is located, is attached in Appendix A.

### 2.2 Owner of Land and Mineral Rights

*Owner of land upon which the development is intended to be constructed, and of mineral rights beneath the land, if different from surface owner:*

The status of title [No. 3201479/1] does not indicate any exclusions, therefore the mines and minerals below the site would be included with the surface title.

### 2.3 Existing Land Use

*Existing land use on the site and on land adjoining it, as well as changes that will be made in such land use for the purposes of the development:*

The land proposed for development is currently a forested area located approximately 100 m northeast of the bottling plant, and 120 m from the nearest residence (which is owned by Clearly Canadian). The development site is surrounded by forest land to the north, east and south with the bottling plant trailers adjacent to the west. The access road is adjacent to the north. The treatment facility is located approximately 360 m from the nearest waterbody (Seine River). Access to the treatment equipment will be from the existing site access road.

### 2.4 Land Use Designation/Zoning Designation

*Land use designation for the site and adjoining land as identified in a development plan adopted under The Planning Act or The City of Winnipeg Act, and the zoning designation as identified in a zoning by-law, if applicable:*

The proposed development site is zoned as Rural Residential, based on zoning designations in the RM of La Broquerie. This zoning designation allows for public utility service, such as a wastewater treatment facility.

## 2.5 Description of Development

*Description of proposed development and schedule for stages of the development, including proposed dates for planning, design, construction, commissioning, operation, and decommissioning and/or termination of operation (if known), identifying major components and activities of the development as applicable (e.g. access road, airstrip, processing facility, waste disposal area, etc.).*

### 2.5.1 Project Schedule

Subject to licence approval from MECC, equipment procurement would begin in the summer of 2026 with installation targeted for fall 2026.

### 2.5.2 Review of System Site Location

The MBBR system will be located on the Clearly Family Beverage Company property, in a currently forested area. The system will have the following setbacks:

- approximately 134 m from the nearest residence on the property
- approximately 176 m from the nearest residence off of the property
- approximately 200 m from the nearest residential street area of Marchand
- approximately 360 m from the Seine River.

The MBBR system will be surrounded by forest land and will be adjacent to an existing access road. Plan 2 in Appendix C, shows the proposed treatment system with setback distances to the nearby residences.

### 2.5.3 Land Classification

The soils at the development site are classified as the Pansy Series, which are sandy lacustrine soils. The land has an agricultural capability of Class 4. Based on the *Nutrient Management Regulation (Reg. 62/2008)* under the Water Protection Act, the land would have a nutrient management zone designation of N2, which would have moderate restrictions for the application of nutrients to the soil through effluent discharge, given that the provincial requirements for effluent quality are met. The residential properties surrounding the bottling plant, utilize septic systems for residential wastewater disposal.

### 2.5.4 Effluent Discharge Route

The proposed wastewater treatment system would discharge into the existing wastewater storage pond on the site. Due to the permeable soils surrounding the pond, it is expected that the effluent will exfiltrate into the surrounding soils and overflow into an existing drainage ditch on the east side of the wastewater pond, which flows east for approximately 230 m towards the Seine River. The existing drainage ditch will continue to be utilized.

### 2.5.5 Treatment System Access

A turnaround area will be constructed to the wastewater treatment tanks to allow for periodic pump out of sludge. A fence with a lockable gate will be installed around the treatment system tanks to prevent unauthorized entry.

## 2.6 Contributing Effluent

The industrial wastewater being sent to the storage pond consists of by-products of the beverage bottling process. This by-product consists mainly of potable water with some chemical cleaners and sugar as a by-product, at a maximum proposed discharge rate of 20 m<sup>3</sup>/day. The chemicals discharged into the system from the plant operations include:

- Super Klenz (Chlorinated Alkaline Detergent)
- Vortexx (Acid Liquid Sanitizer)
- AC55-5 Red (Acid Cleaning Agent).

The residential wastewater from the bottling plant washrooms is currently all directed to a separate septic tank and field located to the west of the plant building, however this wastewater will be directed to the new wastewater treatment system once installed to provide the needed nutrients for bacteria growth.

### 2.6.1 Wastewater Production

The wastewater production flows from the bottling operation were provided by the plant operations manager. The flows to the wastewater pumping tank include:

- Well water (raw and filtered) – 4 days/week, 1 day/month
- Bottle rinse water (with product residue and cleaning agents) – 4 days/week, 4 days/month
- Filtered water (with cleaning agents and product residue) – 4 days/week, 1 day/month.

The bottling plant washrooms consist of toilets, one urinal, and sinks. The number of employees is expected to be 34, and the plant operates five days a week, from Monday to Friday. The flow from the plant employees is expected to be 1.7 m<sup>3</sup>/day, based on 49 L/person/day as per the Manitoba *Onsite Wastewater Management Systems* (July, 2005).

Daily flows to the pumping tank are intermittent and will range based on plant operations, however an expected peak wastewater flow to the system will be 20 m<sup>3</sup>/day in the year 2028 and beyond. If flows are to increase beyond 20 m<sup>3</sup>/day in the future, MECC will be notified for approval, and the treatment system modified to accommodate increased flows, as the system is modular.

## 2.6.2 Raw Wastewater

The wastewater from the pumping tank was sampled in August 2024, May 2025 and November 2025. The pumping tank contained only process wastewater from the bottling operations and no domestic wastewater. The following table summarizes the raw wastewater quality from these sampling events.

**Table 2.1: Raw Process Wastewater Sampling Results from Plant Bottling Operations**

| Raw Wastewater Parameter                     | Units      | August 2024 | May 2025 | November 2025 |
|--|------------|-------------|----------|---------------|
| pH   | pH units   | 6.39        | 6.81     | 6.17          |
| Total Suspended Solids (TSS)                 | mg/L       | 7.6         | 6.2      | 17            |
| Ammonia, total (as N)                        | mg/L       | 0.174       | 0.252    | 0.260         |
| Phosphorus, total                            | mg/L       | 0.304       | 0.080    | 0.143         |
| Coliforms, fecal                             | MPN/100 mL | 1           | <1       | 5             |
| Biological Oxygen Demand (BOD)               | mg/L       | 1980        | 34.2     | 2800          |
| Carbonaceous Biological Oxygen Demand (CBOD) | mg/L       | 1730        | 41.8     | 2420          |

Due to the cleaning agents and sugar used during the plant operations, the process wastewater can vary daily, such as BOD values ranging significantly across sampling events. Design assumptions for treatment were established using current wastewater characteristics and peak loading allowances. The nutrient and suspended solids concentrations are lower than typical residential wastewater.

The wastewater effluent from the washrooms in the bottling plant was not sampled, therefore estimates of wastewater quality was reviewed from the Ontario Building Code for typical domestic wastewater.

**Table 2.2: Estimated Raw Wastewater Characteristics from Plant Washrooms**

| Raw Wastewater Parameter       | Units      | Estimated Range of Concentration |
|--------------------------------|------------|----------------------------------|
| pH                             | pH units   | 7.0 - 8.5                        |
| Total Suspended Solids (TSS)   | mg/L       | 155 - 330                        |
| Ammonia, total (as N)          | mg/L       | 4 - 13                           |
| Phosphorus, total              | mg/L       | 6 - 12                           |
| Coliforms, fecal               | MPN/100 mL | 106 - 108                        |
| Biological Oxygen Demand (BOD) | mg/L       | 155 - 286                        |

## 2.7 Treatment System Design

The treatment system will consist of a moving bed biofilm reactor (MBBR), provided by Waterloo Biofilter, and will be sized to handle peak future loading. The treatment system will consist of a multi-stage tank system with the following configuration:

- Equalization tank – one 18,600 L fibreglass tank for time-dosing the system
- Online sludge storage tank – one 18,600 L fibreglass tank with two chambers for sludge storage
- Offline sludge storage tank – one 40,900 L fibreglass tank with two chambers for secondary sludge storage
- Primary clarifier tank – one 18,600 L fibreglass tank with two chambers for settling out solids
- Biological treatment tank - one 31,800 L fibreglass tank with plastic media and bubble diffusers for aeration in two chambers
- Intermediate clarifier tank – one 18,600 L fibreglass tank for solids settling and recycle to offline sludge storage tank
- Biological treatment tank - one 31,800 L fibreglass tank with plastic media and bubble diffusers for aeration in two chambers
- Final clarifier and pumping tank – one 31,900 L fibreglass tank with two chambers for settling of solids and return to the offline sludge storage tank, and final pumping to the storage pond
- Post phosphorus removal tank – one 3,400 L concrete tank with two chambers for chemical precipitation and mixing.

The tanks used for this application are proposed to be a mix of concrete and fibreglass with a concrete anchor system. The tanks would be buried at the site with insulation installed above the tanks for protection from frost damage. Disinfection would occur by UV units after the final pump tank and would be located in the control building. The system will also utilize a flowmeter and a PLC control panel, along with two air compressors in a control building. A sampling port will be located after the UV treatment unit in the control building. The treated effluent would be pumped to the effluent storage pond continuously, based on the flows into the system. In the storage pond, the liquid would exfiltrate into the ground and would overflow into the adjacent drainage ditch to the east.

The MBBR process is an attached-growth biological treatment technology, where the biomass is retained on the media carriers. This allows the system to be inherently resilient to intermittent flows, and hydraulic variation from the source, as would be the case at the bottling facility, where there are times of low flow or no flow. The biofilm on the media allows the bacterial population to persist for extended periods of time even when the source wastewater flows are interrupted.

## 2.8 Topography and Geotechnical Information

An on-site geotechnical investigation was completed on August 22, 2024. The sections below represent a summary of the topographical and geotechnical findings.

### 2.8.1 Site Conditions and Topography

The lands surrounding the existing wastewater storage pond and proposed development area consisted of forest land and a grassed residential yard. The land was generally flat, but drainage off of the site from the pond is east towards the Seine River from the drainage ditch, and west to the highway ditch along Provincial Road 210.

### 2.8.2 Geotechnical Review

One test hole was drilled on the south side of the existing wastewater storage pond to a depth of 4.5 m. The soil profile consisted of a layer of fine-grain, saturated brown sand just below the surface, overlying a layer of fine-grain, saturated grey sand to the bottom of the test hole. The entire soil profile was wet and saturated, likely indicating exfiltration from the wastewater storage pond. The test hole log is included in Appendix A and the test hole location has been included on Plan 2, Appendix C.

## 2.9 Review of Regulatory Requirements

### 2.9.1 Effluent Quality Requirements

Any new or expanding wastewater treatment systems are required to meet the Manitoba *Water Quality Standards, Objectives and Guidelines - Tier 1 Water Quality Standards* at a minimum, along with the Federal *Wastewater Systems Effluent Regulations*, for discharged effluent. In an Environment Act Licence the effluent requirements for the Clearly Family Beverage wastewater treatment system, at a minimum, would include:

- Fecal coliforms of 200/100 ml or less, or E. coli of 200/100 ml or less
- CBOD of 25 mg/L or less
- TSS of 25 mg/L or less
- Total residual chlorine of 0.02 mg/L or less
- Un-ionized ammonia (as N) of 1.25 mg/L or less, at 15°C
- 1 mg/L total phosphorus or demonstrated nutrient reduction strategy.

Sampling of effluent would be completed after the UV treatment units and the sampling ports would be located in the heated control building (see Plan 4 attached).

### 2.9.2 Nutrient Management Plan

The Manitoba *Water Quality Standards, Objectives, and Guidelines*, 2011, outline the nutrient reduction requirements for effluent in all new, expanding or modified wastewater treatment facilities. The guidelines include province wide standards for biological reduction, suspended solids reduction, phosphorus reduction and where site-specific conditions warrant, nitrogen reduction. The Federal *Wastewater Systems Effluent Regulations*, 2012, outline the limits on un-ionized ammonia concentration in the effluent.

Due to low concentrations of phosphorus in the raw wastewater, chemical phosphorus addition may be required in the treatment system to enhance biological treatment. The domestic wastewater from the plant washrooms will be added to the process wastewater with the goal of reducing or eliminating phosphorus addition. Regardless of the source, phosphorus will require removal prior to discharge. A chemical coagulant and settling will be used to reduce the phosphorus concentration to below 1 mg/L prior to discharge.

Due to low concentrations of ammonia and nitrogen in the raw wastewater, it is expected that an un-ionized ammonia concentration of 1.25 mg/L will be met by the proposed MBBR treatment system prior to discharge.

## **2.10 Existing Storage Pond and Collection System**

The existing wastewater storage pond is a single cell structure excavated in the native sandy soils. The process wastewater from the plant is currently directed by gravity to a buried pumping tank to the north of the plant building, where wastewater is pumped to the storage pond via an underground pipe. The pond has a discharge overflow to a ditch located on the east side of the pond. There were no design drawings available for the pond construction, however from recent pump outs, it is estimated to have a depth of 2.5 m. The pond was recently pumped down and the outer berms built up by approximately 0.3 m to better identify if there are any discharges out of the pond. Prior to the pumping, the pond had several floating vegetation islands on it, likely due to its age and lack of maintenance.

It is proposed that the storage pond would continue to be used for storage of treated effluent from the MBBR treatment system. A dedicated dike overflow would be constructed on the east side of the storage pond to allow continuous discharge of treated effluent to the drainage ditch that flows to the east towards the Seine River. Prior to utilizing the storage pond, the effluent will be pumped out and the floor and slopes of the pond will be dredged of any accumulated sludge. The wastewater pumped out will be hauled to a licenced wastewater treatment lagoon for disposal.

### 3.0 POTENTIAL ENVIRONMENTAL IMPACTS AND MITIGATION MEASURES

*The biophysical and socioeconomic environment as related to the development, and potential impacts of the development on the environment. Proposed environmental management practices to be employed to prevent or mitigate adverse implications from the impacts identified.*

Environmental issues, where they may occur, and mitigating measures where necessary, are presented in the chart on the following pages, which outline the assessment of the expected actions. Environmental features are assessed against the project actions in the chart. The environmental features include: groundwater, surface water, air quality, noise, land/soil, vegetation, wildlife, habitat, special places (cultural, traditional, historic, scientific), health and safety, socio/economic and aesthetics.

Potential ratings of “I” meaning insignificant, “SN” meaning negatively significant, and “SP” meaning positively significant were identified for the environmental issues depending on possible environmental impacts of the project actions on the environmental features. A project action with no potential environmental issues after mitigation measures are applied was considered insignificant. A project action with identified or residual environmental issues after mitigation measures are applied is considered significant. Where a project action with positive impact on the environment or socio-economic aspect is identified, the environmental issue was considered positively significant and the benefits are stated.

The proponent of the development will ensure that the contractor performing the site works is made aware of the potential environmental issues by way of the construction specifications, prior to commencing with the site works, and that mitigation measures discussed below are followed during site works.

The Manitoba Historic Resources Branch was contacted about concerns for historic or heritage resources in the development area. The branch indicated that the potential to impact heritage resources from the proposed site works is low and they have no concerns with the proposed project (see memorandum in Appendix B).

The Manitoba Wildlife Branch was contacted about concerns for species at risk in the development area. The branch provided results of the data centre search for all reported species at risk recorded within 5 km (see database results in Appendix B). The recorded observations were from 1953 to 2023. The results indicated these four species recorded in the vicinity of the Clearly Canadian Beverage Company property:

- Narrow-leaved Agalinis (S3 – vulnerable) (1989) – purple flower found in brackish marshes, meadows, fields and woodlands
- Great Northern Aster (S2 – imperiled) (1953) – purple flower found in moist forests, marshes and along streams
- Houghton’s Flatsedge (S2 – imperiled) (1989) – white flower found on ridges, river banks and woodlands
- Northern Leopard Frog (S4 – apparently secure) (2011) – spotted frog found in ponds, marshes and woodlands.

**Table K: Potential Impacts, Mitigating Measures and Residual Effects**

| Project Action  | Environmental                |  | Rating | Mitigating Measures   |
|---|------------------------------|--|--------|---|
|   | Feature                      | Issue  |        |   |
| 1 Clearing, excavation, installation of a treatment system, piping, and fencing | Groundwater or Surface Water | Contamination from fuel handling spills            | I      | Handling and storage of petroleum products will be conducted according to federal ( <i>Storage Tank Systems for Petroleum Products and Allied Petroleum Products Regulations</i> ) and provincial ( <i>Storage and Handling of Petroleum Products and Allied Products Regulation</i> ) regulations. A spill clean-up kit will be present at the construction site to contain liquid spills. The Manitoba spills reporting unit (204-944-4888) will be contacted in the event of a chemical spill or leak. In the event of a spill, efforts will be made to contain and clean up the spill as soon as possible in a safe manner and haul the contaminated soils to a designated soil treatment facility. |
|   |                              | Contamination from construction equipment leaks    | I      | Contractor is to ensure construction equipment is inspected regularly and maintained in proper working condition to prevent leaking fluids onto the ground.<br><br>Any leaks will be contained and cleaned up in a timely manner to ensure groundwater or surface water is not impacted. A spill clean-up kit is to be located onsite.  |
|   | Soil/Surface Water           | Siltation from soil erosion and site disturbance   | I      | Silt fencing would be installed in any drainage ditches adjacent to the construction to control sediment runoff into adjacent surface water bodies during construction and installation works. Any bare ground exposed through site works, will be re-vegetated with grass seed as soon as construction is complete to prevent future erosion. The silt fencing will remain in place until surface vegetation is re-established on disturbed areas.<br><br>Any stockpiled soil should be placed away from drainage features and be covered with tarps or erosion control blankets or re-seeded with grass.  |
|   |                              |  |        | Air Quality   |
|   | Air Quality                  | Emissions from Construction Equipment and Vehicles | I      | The contractor is to ensure construction equipment is properly maintained and that emissions from construction equipment are to comply with federal, provincial and local emissions standards, and are not a nuisance to nearby residents. Vehicle idling will be kept at a minimum during construction works.  |
|   |                              | Odours   | I      | The treatment system will be aerated and contained in a tank system during treatment to limit the potential for odour generation. The existing storage pond will be pumped out, dredged and used for treated effluent only, reducing the likelihood of odours.  |

| Project Action              | Environmental |   | Rating | Mitigating Measures   |
|-----------------------------|---------------|---|--------|---|
|                             | Feature       | Issue                                   |        |   |
| 1 Construction Works cont'd | Noise         | Disturbance from Construction Equipment |        | Noise impacts are to be mitigated by operating construction equipment with engine mufflers in good working order. Construction works are to be completed during daylight hours only (between 7 am and 7 pm), unless approved by the RM of La Broquerie for specific tasks. Neighboring residents will be informed of the construction schedule.   |
|                             | Land/Soil     | Land Alteration/Soil Erosion            |        | Any excess excavated soil material should be temporarily stockpiled and used on the property for landscaping or drainage control. Any stockpiles are to be covered by tarps or temporary erosion control blankets or re-seeded. Temporary soil stockpiles will not be located adjacent to the drainage ditching.<br><br>Any bare soil at the site from construction disturbance will be re-seeded to prevent future soil erosion.   |
|                             | Soils         | Encountering Contaminated Soils         |        | If contaminated soils are encountered during excavation, works should be halted in the area of encounter and the Engineer will be notified along with any related provincial/federal authorities, as applicable. The extent of contamination will be determined through soil sampling and lab analysis for petroleum hydrocarbons, in accordance with CCME <i>Guidance Manual for Environmental Site Characterization in Support of Environmental and Human Health Risk Assessment</i> , and the Manitoba <i>Contaminated Sites Remediation Regulation</i> . Contaminated material would be removed and properly disposed of at a licenced facility. Once the area has been restored, works in the area would resume. |

| Project Action              | Environmental                   |  | Rating | Mitigating Measures  |
|-----------------------------|---------------------------------|--|--------|--|
|                             | Feature                         | Issue  |        |  |
| 1 Construction Works cont'd | Health and Safety               | Construction Hazards                                   | 1      | <p>To mitigate any impacts on health and safety and public hazards the following mitigating measures are to be used:</p> <ul style="list-style-type: none"> <li>• Manitoba Workplace Safety and Health Act and Regulation 217/2006 are to be applied regarding health and safety of operators, employees and the general public at the work sites</li> <li>• The contractor is to abide by a health and safety program during construction works, which includes safety meetings, safety training, having first aid/CPR trained personnel onsite</li> <li>• Access to the construction areas will be limited by fencing and signage</li> <li>• Ensure all workers and visitors utilize appropriate PPE in the construction areas</li> <li>• Construction works are to be completed during daylight hours only</li> <li>• Any spills will be contained and cleaned up immediately, and proper authorities notified</li> <li>• Spill cleanup kits and fire extinguishers will be available during the construction works</li> </ul> <p>Any serious injuries, incidents or fatalities are to be reported immediately to Manitoba Workplace Safety and Health, and the Workers Compensation Board of Manitoba.</p> |
|                             | Heritage and Historic Resources | Discovery of Historic or Cultural Artifacts or Remains | 1      | <p>If any archaeological, cultural or historical artifacts are uncovered during construction, works are to temporarily cease in those areas and the Manitoba Historic Resources Branch will be contacted immediately, along with the property owner, RM and any applicable provincial or federal authority, to examine the site and determine a proper course of action prior to works commencing in the area. If human remains are found, the RCMP would be contacted immediately for investigation. The Manitoba Historic Resources Branch indicated that the potential impact to heritage resources from the works is low (see Memorandum in Appendix B).</p>   |

| Project Action              | Environmental             |                                       | Rating | Mitigating Measures  |
|-----------------------------|---------------------------|---------------------------------------|--------|--|
|                             | Feature                   | Issue                                 |        |  |
| 1 Construction Works cont'd | Vegetation                | Removal                               | I      | <p>The removal of vegetation should be limited to the development area. Vegetation outside of the development area is to be protected from removal and damage by clearly marking the area of disturbance and the limits of clearing.</p> <p>Silt fencing should be utilized in drainage ditches or channels to reduce impacts of siltation to aquatic vegetation in downstream surface waters.</p> <p>If any plant species at risk is identified during the construction works, the works would temporarily cease in that area, pictures of the plant species would be taken, and the Manitoba Fish and Wildlife branch will be contacted to determine identification and a suitable course of action.</p>   |
|                             | Wildlife and Birds        | Disturbance                           | I      | <p>The surrounding lands are forested and partially cleared for residential and commercial purposes. A desktop search for species at risk identified the Northern Leopard Frog (G5: Secure) potentially located in the region in areas with standing water. There are not expected to be any impacts to natural waterways from the development, which could impact this species. The continued use of the wastewater storage pond for treated effluent will provide additional habitat for waterfowl and amphibians.</p> <p>Construction activities will be limited to the development areas by clearly marking the limits of construction. If species, nests or habitats are identified, construction will be avoided in these areas, if possible, or MECC Wildlife Branch will be contacted for guidance.</p> <p>Construction activities should be limited to daylight hours only so any species encountered can be visually identified. Any bird or wildlife species, eggs and habitat areas will not be intentionally disturbed or destroyed. The construction areas will be kept free of garbage and food wastes that may attract wildlife.</p> |
|                             | Fish Habitat/Aquatic Life | Habitat Alteration and/or Disturbance | I      | <p>The nearest body of surface water with suspected fish species would be the Seine River, located approximately 450 m from the treatment system and 230 m from the effluent storage pond. Siltation in the drainage route will be reduced through the use of silt fencing during the construction works. In accordance with subsection 36(3) of the Fisheries Act, no deleterious substance is to be deposited in a body of water that contains fish species. If any deleterious substance is deposited in a body of water, the contractor will contact DFO to report and take all reasonable measures to counteract, mitigate and remedy any adverse effects.</p>  |
|                             | Social                    | Heavy Equipment Traffic               | I      | <p>Construction works and travel will be limited to daylight hours only. The contractor will be made aware of travelling with caution in residential areas while hauling equipment and materials. Local traffic on the property should not be affected.</p>  |
|                             |                           | Interruption of Wastewater Service    | I      | <p>The contractor will provide temporary sewer service such as truck pumping and hauling, during connection of the wastewater piping.</p>  |

| Project Action                             | Environmental |                             | Rating | Mitigating Measures  |
|--|---------------|-----------------------------|--------|--|
|  | Feature       | Issue                       |        |  |
| 1 Construction Works cont'd                | Aesthetics    | Degradation of View         | I      | The disturbed areas in the development will be re-seeded and restored to a natural state. The owner is not concerned about the view of several tank manholes from the treatment system on their property.  |
|  |               | Site Cleanliness            | I      | The contractor will ensure that the construction site is properly cleaned up of all rubbish, excess materials and temporary structures prior to leaving the site. Any construction materials requiring disposal will be sent to a licenced landfill site. Any hazardous waste material will be hauled to a hazardous waste facility.   |
| 2 Operation of Wastewater Treatment System | Surface Water | Contamination from effluent | I      | The wastewater effluent will be treated to meet all provincial and federal guidelines for surface discharge. The operator will test the effluent regularly to ensure that concentrations meet the Environment Act Licence requirements. The MBBR system is inherently resilient to intermittent flows due to the biofilm in the system, which can survive periods of low flow.<br><br>Sludge in the tanks will be pumped out regularly and hauled to a local wastewater treatment lagoon for disposal. |
|  | Social        | Operator Training           | SP     | The wastewater treatment system operator will be certified to the level specified by the province and trained by the system supplier. The operators are to work with Health Canada and MECC to ensure proper operation, maintenance, sampling/testing and emergency protocols are in place.  |

## 4.0 RESIDUAL AND CUMULATIVE EFFECTS

*Residual environmental effects remaining after the application of mitigation measures, to the extent possible expressed in quantitative terms relative to baseline conditions*

With the proposed treatment system, pond rehabilitation, monitoring and licence conditions, residual effects are expected to be negligible. Positive residual effects are expected from a treatment system that is producing effluent that meets provincial and federal wastewater effluent guidelines.

No negative cumulative effects are anticipated from other construction works in the area. As the treatment system is modular, it can be expanded in the future for additional flows if the plant decides to increase production, by installing additional treatment tanks.

## 5.0 MONITORING AND FOLLOW-UP

*Proposed follow-up activities that will be required at any stage of development (eg. Monitoring, inspection, surveillance, audit, etc.).*

Monitoring of the wastewater treatment system operation is to be conducted by trained maintenance employees at the bottling plant, who are certified by the province for operating the WWTP. The operators will ensure the system is operated under the requirements of the Environment Act licence, with the assistance of the system supplier and installer. The system manufacturer will complete start up sampling and will train the site operators to maintain the system and sample regularly. The system will have an accessible area to sample effluent after the UV disinfection. The sampling frequency will be determined by the Environment Act Licence.

The operators are to:

- ensure the pumps in the treatment system tanks are operating properly
- ensure screens are cleaned regularly
- ensure sludge is pumped out regularly
- conduct sampling of treated effluent regularly
- ensure water quality parameters as described in the Environment Act licence are met
- maintain records of sampling events and water quality monitoring for reporting to MECC and Environment Canada (as required).

If there are any concerns with the operation of the treatment system, the owner is to contact the system supplier and local MECC enforcement officer to discuss mitigation options.

## 6.0 FUNDING AND APPROVALS

*Name and address of any Government Agency or program (federal, provincial or otherwise) from which a grant or loan of capital funds have been requested (where applicable). Other federal, provincial or municipal approvals, licences, permits, authorizations, etc. known to be required for the proposed development, and the status of the project's application or approval.*

Funding for the wastewater treatment system will be provided by the owner. The proponent will obtain all applicable approvals associated with the installation and operation of the treatment system and any related site works. The owner is responsible for registering the treatment system with Environment Canada and providing annual monitoring reports to Environment Canada under the *Federal Wastewater Systems Effluent Regulations*.

## 7.0 PUBLIC CONSULTATION

*Results of any public consultations undertaken or to be undertaken in conjunction with project planning.*

The owner will contact the neighboring residents to inform of the project and the timing of the public posting for comments. Public comments will be received by MECC through the public registry during the Environmental Act Proposal review period.

## 8.0 CONCLUSION

Based on the design of the project, and the implementation of the mitigation measures identified in Section 3.0 above, no significant negative environmental impacts are anticipated.

The proponent would like to complete the requirements of the Environment Act Proposal by the spring of 2026, so that the wastewater treatment system equipment can be ordered, manufactured and shipped for installation by the summer/fall of 2026, under an Environment Act Licence.

JR Cousin Consultants Ltd. requests that a draft copy of the Environment Act Licence be forwarded for review prior to the issuing of the final licence.

# **APPENDIX**

## **Appendix A**

Status of Title

Test Hole Log, JR Cousin Consultants Ltd., August 22, 2024

## **Appendix B**

Manitoba Historic Resources Branch, Memorandum. December 23, 2025

Manitoba Wildlife Branch, Data Centre Records. December 17, 2025

## **Appendix C**

Title Page

Plan 1: Site Location Plan

Plan 2: MBBR Layout Plan with Residential Setbacks and Drainage Route

Plan 3: Tank Layout Plan

Plan 4: UV Disinfection and Sampling Port Detail

## **Appendix A**

Status of Title

Test Hole Log, JR Cousin Consultants Ltd., August 22, 2024

Status of Title

## STATUS OF TITLE

Title Number      **3201479/1**  
Title Status        **Accepted**  
Client File         **0155882.00001/CF/JG**



### 1. REGISTERED OWNERS, TENANCY AND LAND DESCRIPTION

CLEARLY FAMILY BEVERAGE COMPANY ULC

IS REGISTERED OWNER SUBJECT TO SUCH ENTRIES RECORDED HEREON  
IN THE FOLLOWING DESCRIBED LAND:

SP LOT 3 BLOCK 1 PLAN 16583 WLTO  
E 1/2 OF SECTION 3-6-8 EPM

The land in this title is, unless the contrary is expressly declared, deemed to be subject to the reservations and restrictions set out in section 58 of *The Real Property Act*.

### 2. ACTIVE INSTRUMENTS

Instrument Type:      **Caveat**  
Registration Number:   **265460/1**  
Instrument Status:     **Accepted**

Registration Date:     **1979-10-22**  
From/By:                **RUDOLF G. DYCK**  
To:

Amount:  
Notes:                  **No notes**  
Description:            **No description**

Instrument Type:      **Caveat**  
Registration Number:   **265461/1**  
Instrument Status:     **Accepted**

Registration Date:     **1979-10-22**  
From/By:                **GORDON P. DYCK**  
To:

Amount:  
Notes:                  **No notes**  
Description:            **No description**

Instrument Type: **Caveat**  
Registration Number: **3363583/1**  
Instrument Status: **Accepted**

Registration Date: 2006-10-12  
From/By: THEODURUS JOSEPHUS MARIA VAN DER VELDT  
To:

Amount:  
Notes: No notes  
Description: RIGHT OF WAY AGREEMENT

Instrument Type: **Caveat**  
Registration Number: **4041305/1**  
Instrument Status: **Accepted**

Registration Date: 2011-02-24  
From/By: SYLVIA ROSE BALCAEN  
To: GERALD J.SIMARD AS AGENT

Amount:  
Notes: SERVIENT  
Description: RIGHT OF WAY AGREEMENT

**3. ADDRESSES FOR SERVICE**

CLEARLY FAMILY BEVERAGE COMPANY ULC  
2967 Dundas St. W.  
#390D  
Toronto ON  
M6P 1Z2

**4. TITLE NOTES**

No title notes

**5. LAND TITLES DISTRICT**

Winnipeg

**6. DUPLICATE TITLE INFORMATION**

Duplicate not produced

**7. FROM TITLE NUMBERS**

2700887/1 All

**8. REAL PROPERTY APPLICATION / CROWN GRANT NUMBERS**

No real property application or grant information

**9. ORIGINATING INSTRUMENTS**

Instrument Type: **Transfer Of Land**  
Registration Number: **5454875/1**

Registration Date: **2022-08-05**  
From/By: **LIESVELD HOLSTEINS INC.**  
To: **CLEARLY FAMILY BEVERAGE COMPANY ULC**  
Consideration: **\$242,000.00**

**10. LAND INDEX**

Lot 3 Block 1 Plan 16583

CERTIFIED TRUE EXTRACT PRODUCED FROM THE LAND TITLES DATA STORAGE  
SYSTEM OF TITLE NUMBER 3201479/1

Test Hole Log, JR Cousin Consultants Ltd., August 22, 2024

# TEST HOLE LOG SHEET

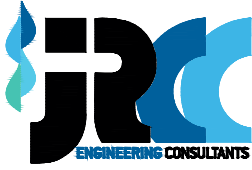

CLIENT NAME: CLEARLY FAMILY BEVERAGES Co ULC  
 PROJECT NAME: WASTEWATER LAGOON EAP  
 PROJECT CODE: C-863.01  
 METHOD OF SAMPLING: OPEN CUT

TEST HOLE: 01  
 DATE: 2024-08-22  
 ELEVATION: 298.600  
 LOCATION: N = 5480762.200  
 E = 686708.300

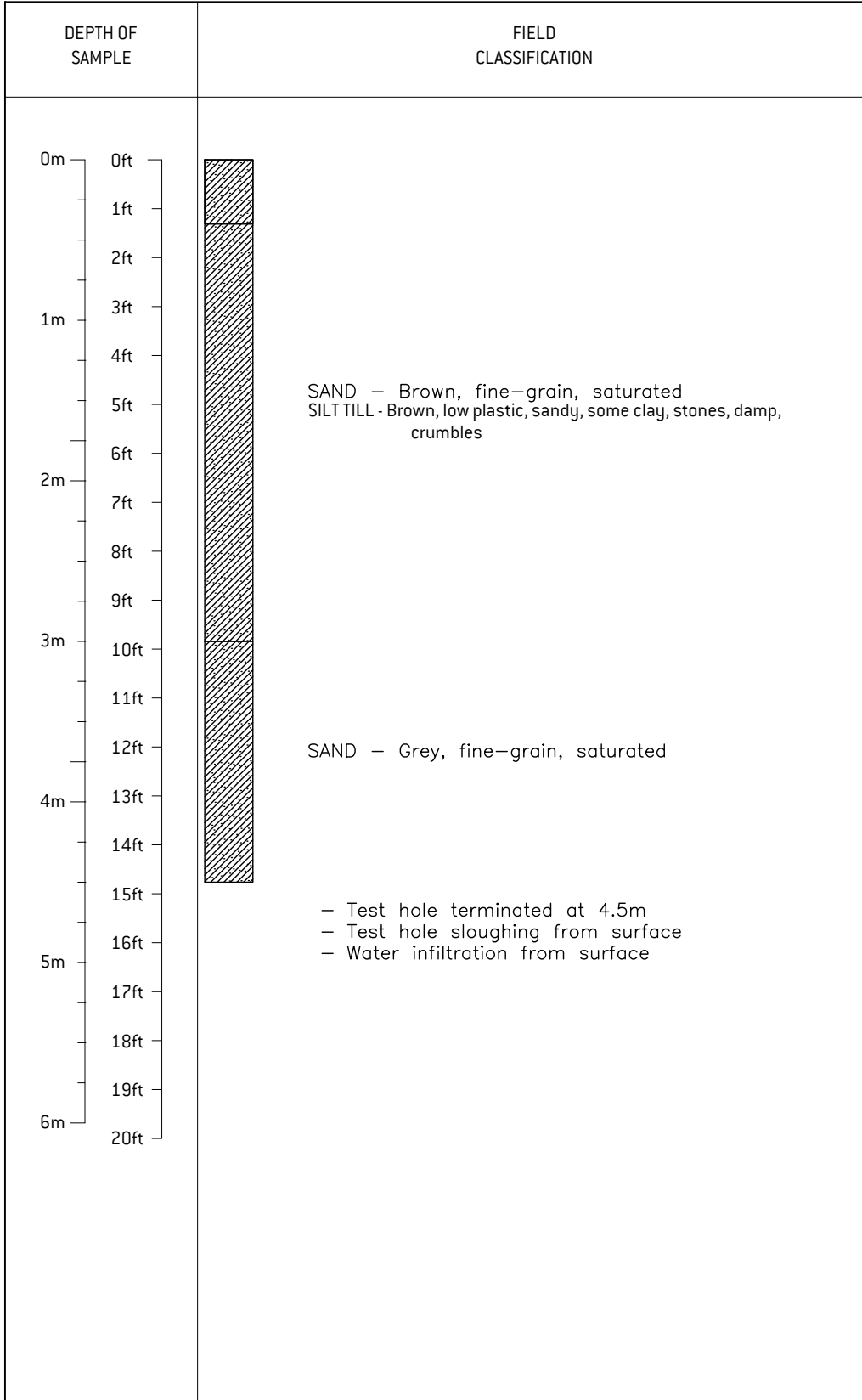

|         |                    |
|---------|--------------------|
|         |                    |
| GW      | GP                 |
|         |                    |
| GM      | GC                 |
|         |                    |
| SW      | SP                 |
|         |                    |
| SM      | SC                 |
|         |                    |
| ML      | CL                 |
|         |                    |
| OL      | CI                 |
|         |                    |
| MH      | CH                 |
|         |                    |
| OH      | PT                 |
|         |                    |
| Topsoil | Static Water Level |

The soil logs are based upon objective data available to us at the time of forming our opinions. The soil logs indicate site specific soil characteristics and must not be generalized over larger areas do to the limited number of test holes as compared to that of an unlimited number of test holes. Every effort is made to evaluate the information by methods generally recognized. The soil logs represent our opinions. JR Cousin Consultants Ltd. cannot be responsible for actual site conditions proved to be materially at variance from our analysis or from the data generalization over untested areas.

## **Appendix B**

Manitoba Historic Resources Branch, Memorandum, December 23, 2025

Manitoba Wildlife Branch, Data Centre Records, December 17, 2025

Manitoba Historic Resources Branch, Memorandum. December 23, 2025

**DATE:** 2025-12-23

**TO:** JR Cousin Consultants Ltd.  
Attn: Oswald Wohlgemut  
Environmental Scientist  
91-A Scurfield Blvd.,  
Winnipeg MB R3Y 1G4

**FROM:** Archaeological Assessment Services Unit  
Historic Resources Branch  
Manitoba Sport, Culture, Heritage and Tourism  
Main Floor – 213 Notre Dame Avenue  
Winnipeg, MB  
R3B 1N3

**FOR:** Clearly Canadian Beverage  
Company

T: (204) 945-2118 F: (204) 948-2384  
e: HRB.archaeology@gov.mb.ca

**SUBJECT:** Wastewater System Environmental Review – Potential Environmental Act Proposal  
AAS File AAS-25-24887  
Clearly Canadian Beverage Company

### No Concerns at this Time

Further to your e-mail regarding the above-noted application, the Manitoba Historic Resources Branch (HRB) has examined the location in conjunction with Branch records for areas of potential concern. The potential to impact to heritage resources is believed to be low based on analysis of current data and evaluated by the type of action proposed, therefore, the HRB has no concerns with the proposed project at this time. This evaluation is only appropriate for the two footprint locations communicated to HRB in this respective request.

### Legislation

Under Section 46 and 51 of [the Heritage Resources Act](#) (the Act), if at any time, heritage resources are encountered in association with these lands during testing and development, there is an obligation to report any heritage resources and a prohibition on destruction, damage or alteration of said resources. HRB may require that an acceptable heritage resource management strategy be implemented by the proponent/developer to mitigate the effects of their activity on the heritage resources.

If you have any questions, please contact HRB as above for proper assignment and queuing.

*Historic Resources Branch  
Archaeological Assessment Services Unit*

Manitoba Wildlife Branch, Data Centre Records, December 17, 2025

Request: O Wohlgemut Cousin 251201 Marchand clearly can ww treat sys

Location: SE-03-006-08E1, near Marchand

Notes:

| SEARCH CRITERIA        | SITE           | SCINAME                    | COMNAME                  | S_RANK ESEA | SARA            | COSEWIC         | FIRSTOBS  | LASTOBS   |
|------------------------|----------------|----------------------------|--------------------------|-------------|-----------------|-----------------|-----------|-----------|
| Within                 | SE-03-006-08E1 | Agalinis tenuifolia        | Narrow-leaved Agalinis   | S3          |                 |                 | 8/20/1989 | 8/20/1989 |
| Within                 | SE-03-006-08E1 | Canadanthus modestus       | Great Northern Aster     | S2          |                 |                 | 8/11/1953 | 8/11/1953 |
| Within                 | SE-03-006-08E1 | Cyperus houghtonii         | Houghton's Flatsedge     | S2S3        |                 |                 | 8/7/1989  | 8/7/1989  |
| Within                 | SE-03-006-08E1 | Lithobates pipiens         | Northern Leopard Frog    | S4          | Special Concern | Special Concern | 4/28/2011 | 4/28/2011 |
| Within 5km radius of s | SE-03-006-08E1 | Agalinis tenuifolia        | Narrow-leaved Agalinis   | S3          |                 |                 | 8/20/1989 | 8/20/1989 |
| Within 5km radius of s | SE-03-006-08E1 | Ambystoma tigrinum         | Eastern Tiger Salamander | S3?         | Endangered      | Endangered      | 1990      | 1990      |
| Within 5km radius of s | SE-03-006-08E1 | Antrostomus vociferus      | Eastern Whip-poor-will   | S2S3B       | Threatened      | Special Concern | 6/2/2010  | 8/2/2012  |
| Within 5km radius of s | SE-03-006-08E1 | Bombus terricola           | Yellow-banded Bumble Bee | S3S5        | Special Concern | Special Concern | 7/2/1972  | 5/10/1994 |
| Within 5km radius of s | SE-03-006-08E1 | Canadanthus modestus       | Great Northern Aster     | S2          |                 |                 | 8/11/1953 | 8/11/1953 |
| Within 5km radius of s | SE-03-006-08E1 | Chelydra serpentina        | Snapping Turtle          | S3          | Special Concern | Special Concern | 6/5/2012  | 6/5/2012  |
| Within 5km radius of s | SE-03-006-08E1 | Contopus virens            | Eastern Wood-pewee       | S3B         | Special Concern | Special Concern | 6/6/2011  | 6/30/2023 |
| Within 5km radius of s | SE-03-006-08E1 | Cyperus houghtonii         | Houghton's Flatsedge     | S2S3        |                 |                 | 8/7/1989  | 8/7/1989  |
| Within 5km radius of s | SE-03-006-08E1 | Dolichonyx oryzivorus      | Bobolink                 | S3S4B       | Threatened      | Special Concern | 6/5/2012  | 6/8/2012  |
| Within 5km radius of s | SE-03-006-08E1 | Elymus lanceolatus         | Thick-spike Wildrye      | S3          |                 |                 | 8/15/2014 | 8/15/2014 |
| Within 5km radius of s | SE-03-006-08E1 | Lithobates pipiens         | Northern Leopard Frog    | S4          | Special Concern | Special Concern | 4/28/2011 | 4/28/2011 |
| Within 5km radius of s | SE-03-006-08E1 | Melanerpes erythrocephalus | Red-headed Woodpecker    | S3B         | Threatened      | Endangered      | 6/4/2012  | 6/4/2012  |
| Within 5km radius of s | SE-03-006-08E1 | Salix eriocephala          | Heart-leaved Willow      | S2S3        |                 |                 | 8/15/2014 | 8/15/2014 |
| Within 5km radius of s | SE-03-006-08E1 | Tympanuchus phasianellus   | Sharp-tailed Grouse      | S5          |                 |                 | 4/3/1968  | 5/4/2013  |
| Within 5km radius of s | SE-03-006-08E1 | Vermivora chrysoptera      | Golden-winged Warbler    | S2S3B       | Threatened      | Threatened      | 6/3/2010  | 7/4/2023  |

## **Appendix C**

Title Page

Plan 1: Site Location Plan

Plan 2: MBBR Layout Plan with Residential Setbacks and Drainage Route

Plan 3: Tank Layout Plan

Plan 4: UV Disinfection and Sampling Port Plan

# CLEARLY FAMILY BEVERAGES CO ULC

## WASTEWATER TREATMENT SYSTEM ENVIRONMENT ACT PROPOSAL

### PLAN INDEX

- PLAN 1. SITE LOCATION PLAN
- PLAN 2. MBBR LAYOUT PLAN WITH RESIDENTIAL SETBACKS AND DRAINAGE ROUTE
- PLAN 3. TANK LAYOUT PLAN
- PLAN 4. UV DISINFECTION AND SAMPLING PORT PLAN

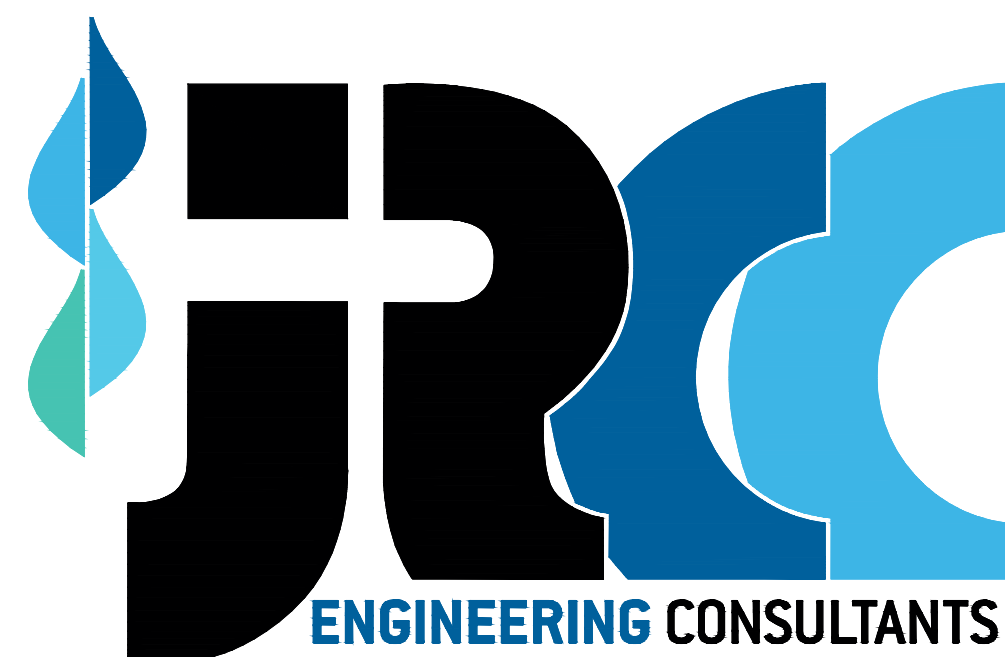

**JR Cousin Consultants Ltd.**

91A Scurfield Blvd. Winnipeg MB R3Y 1G4

p. (204) 489-0474

f. (204) 489-0487

[www.jrcc.ca](http://www.jrcc.ca)

ENGINEERING EXCELLENCE SINCE 1981



PROPERTY BOUNDARY

STORAGE POND

RESIDENCE

TRAILERS

BOTTLING PLANT

SEINE RIVER

PR #210

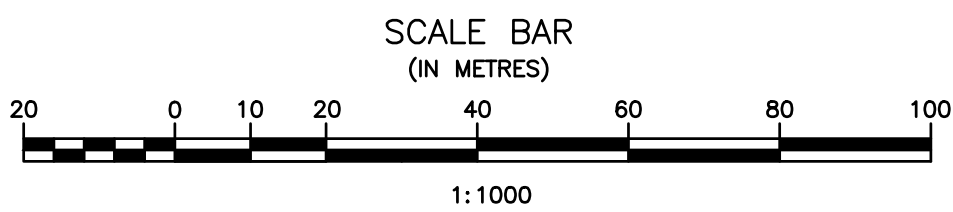

| No. | REVISIONS | DATE | INITIALS |
|-----|-----------|------|----------|
|     |           |      |          |
|     |           |      |          |
|     |           |      |          |
|     |           |      |          |

B.M. EL.

LOCATIONS OF UNDERGROUND STRUCTURES/UTILITIES AS SHOWN ARE BASED ON AVAILABLE INFORMATION BUT NO GUARANTEE IS GIVEN OR IMPLIED THAT ALL EXISTING UNDERGROUND STRUCTURES/UTILITIES ARE SHOWN OR THAT THE GIVEN LOCATIONS ARE EXACT. CONFIRMATION OF EXISTENCE AND EXACT LOCATION OF ALL UNDERGROUND STRUCTURES/UTILITIES MUST BE OBTAINED FROM THE APPROPRIATE AUTHORITY/OWNER, BY THE CONTRACTOR, BEFORE PROCEEDING WITH CONSTRUCTION.

ENGINEER'S SEAL  
**PRELIMINARY**

**JR Cousin Consultants Ltd.**  
 91A Scurfield Blvd. Winnipeg MB R3Y 1G4  
 p. (204) 489-0474  
 f. (204) 489-0487  
 www.jrcc.ca

**ENGINEERING CONSULTANTS** ENGINEERING EXCELLENCE SINCE 1981

|                    |  |
|--------------------|--|
| CODE:<br>C-863.01  | PROJECT:<br>CLEARLY FAMILY BEVERAGE CO ULC<br>WASTEWATER TREATMENT SYSTEM ENVIRONMENTAL ACT RPOPOSAL |
| DESIGNED BY:<br>OW | TITLE:<br>SITE LAYOUT PLAN   |
| DRAWN BY:<br>OT    | SCALE:<br>1:1000   |
| REVIEWED BY:<br>OW | DATE:<br>26/02/27  |
|                    | PLAN:<br>1   |
|                    | SHEET:<br>1 of 2   |



Mar 26, 2024 - 11:45am - 01/03/2024 - Clearly Family Beverages Co. LUT/063.01 Westmanster Lagoon EAP/CA - Design/Plan/Design Plan/02/24 - Layout Plan with MBBR Layout/Design

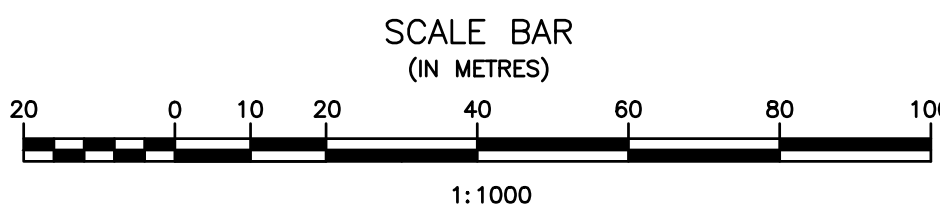

| No. | REVISIONS | DATE | INITIALS |
|-----|-----------|------|----------|
|     |           |      |          |
|     |           |      |          |
|     |           |      |          |
|     |           |      |          |

B.M. EL.

LOCATIONS OF UNDERGROUND STRUCTURES/UTILITIES AS SHOWN ARE BASED ON AVAILABLE INFORMATION BUT NO GUARANTEE IS GIVEN OR IMPLIED THAT ALL EXISTING UNDERGROUND STRUCTURES/UTILITIES ARE SHOWN OR THAT THE GIVEN LOCATIONS ARE EXACT. CONFIRMATION OF EXISTENCE AND EXACT LOCATION OF ALL UNDERGROUND STRUCTURES/UTILITIES MUST BE OBTAINED FROM THE APPROPRIATE AUTHORITY/OWNER, BY THE CONTRACTOR, BEFORE PROCEEDING WITH CONSTRUCTION.

ENGINEER'S SEAL

PRELIMINARY

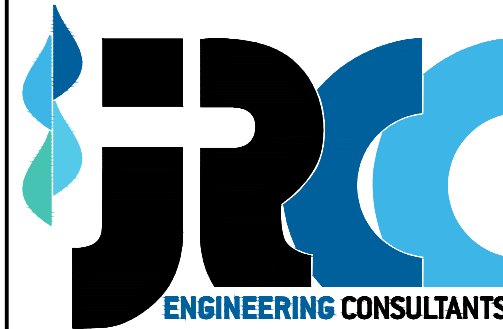

**JR Cousin Consultants Ltd.**  
 91A Scurfield Blvd. Winnipeg MB R3Y 1G4  
 p. (204) 489-0474  
 f. (204) 489-0487  
 www.jrcc.ca

|              |          |          |   |
|--------------|----------|----------|---|
| CODE:        | C-863.01 | PROJECT: | CLEARLY FAMILY BEVERAGE CO ULC WASTEWATER TREATMENT SYSTEM ENVIRONMENTAL ACT PROPOSAL |
| DESIGNED BY: | OW       | TITLE:   | MBBR LAYOUT PLAN WITH RESIDENTIAL SETBACKS AND DRAINAGE ROUTE                         |
| DRAWN BY:    | OT       | SCALE:   | 1:1000  |
| REVIEWED BY: | OW       | DATE:    | 26/02/27  |
|              |          | PLAN:    | 2   |
|              |          | SHEET:   | 2 of 2  |

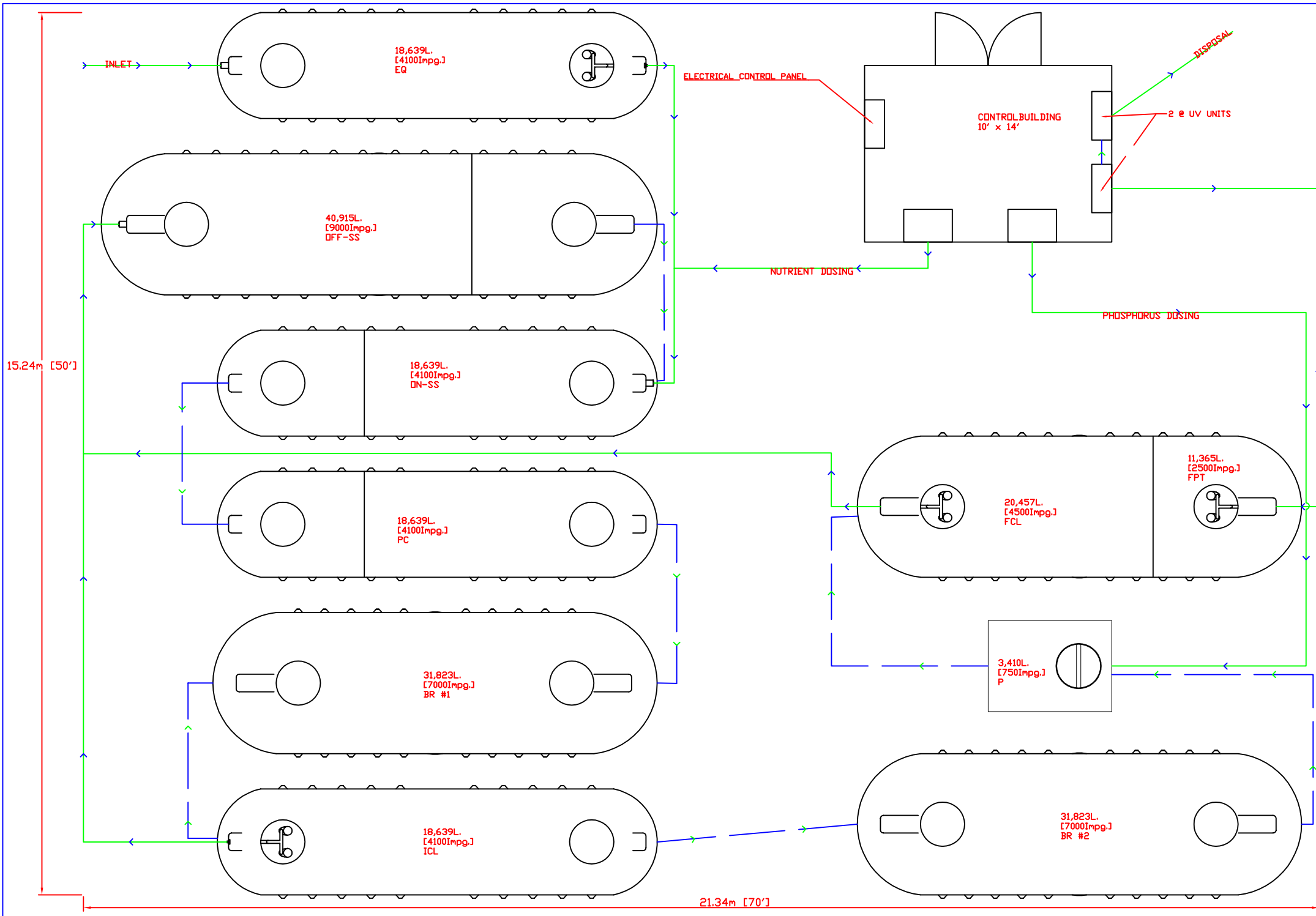

0.15m (6") DROP BETWEEN TANKS FOR GRAVITY DRAIN. TOTAL DROP FROM OFF-SS TANK TO FCL/FPT TANK IS 1.1m (42").

FIRST TANK HAS 0.9m (36") OF OVERBURDEN, LAST TANK HAS 2.13m (7') OVERBURDEN.

PUMPED ———  
GRAVITY - - - - -

|   |                             |                                      |
|---|-----------------------------|--------------------------------------|
| <p><b>Concrete &amp; Fiberglass Products Ltd.</b><br/>         712 KENNEDY RD. WINNIPEG BEACH, MB R0C 3G0<br/>         PH: (204) 389-8651 FAX: (204) 389-6688<br/>         EMAIL: INFO@DLPRODUCTS.CA WEBSITE: WWW.DLPRODUCTS.CA</p> |                             |                                      |
| CLEARLY FAMILY BEVERAGE<br>20 m3/d<br>QUOTE: MB-C-2025-0005   | DATE: _____<br>SCALE: _____ | DRAWN BY:<br>AZ<br>PAGE:<br>-- OF -- |

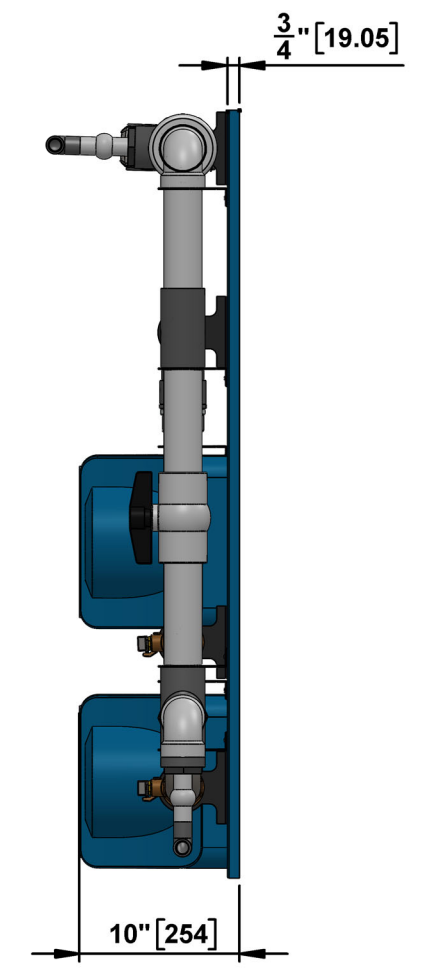
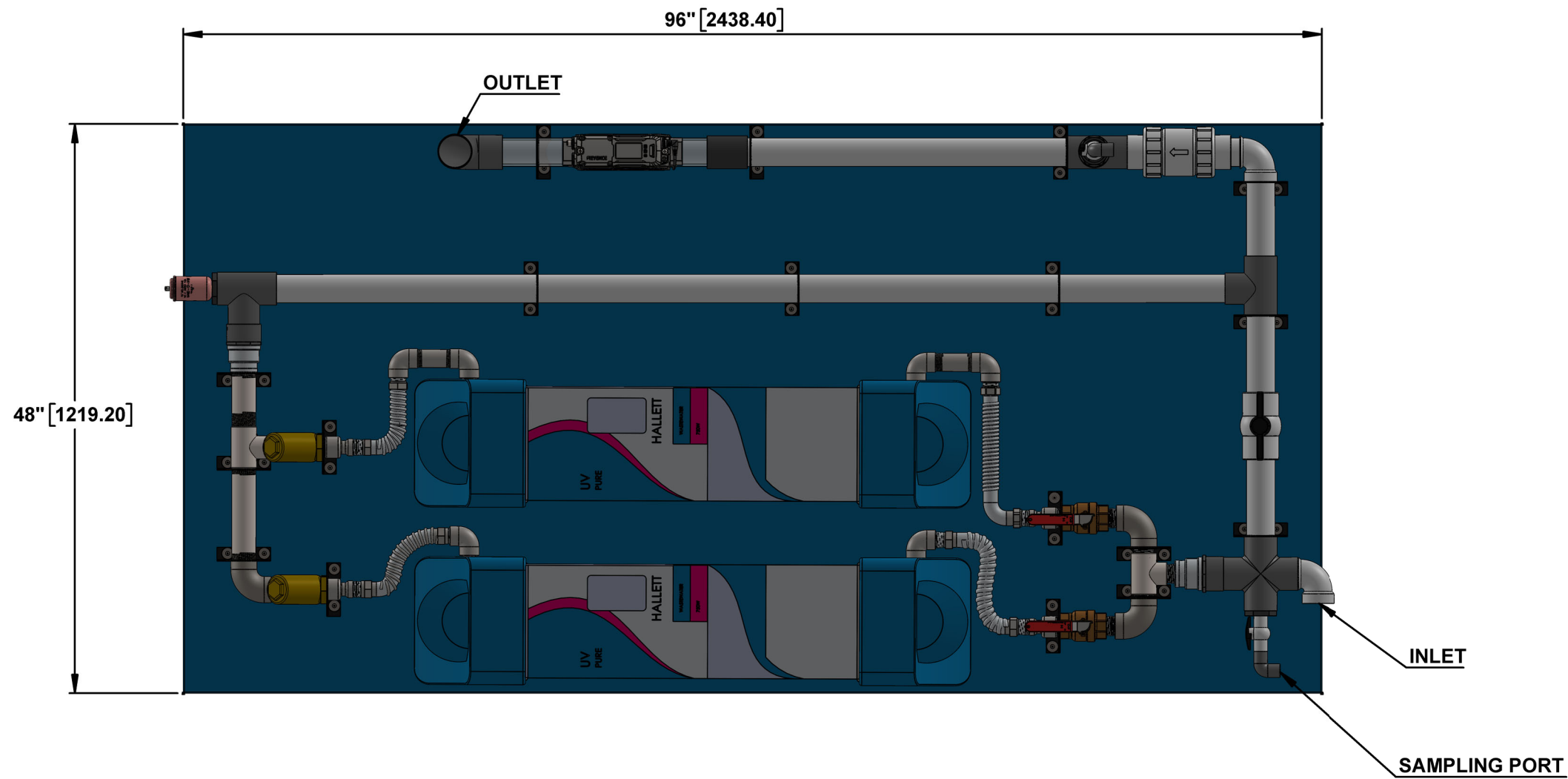

|                         |               |          |           |                            |                        |             |
|-------------------------|---------------|----------|-----------|----------------------------|------------------------|-------------|
| Third Angle Projection: | Approved By   | Initials | Date      | Drawing:                   | Author: P. Bhogal      | A3          |
|                         | Eng. Manager  | B.S      | 3/23/2026 | UV Board Assembly          | Last Updated: 4/8/2022 |             |
|                         | Prod. Manager | J.G      | 3/23/2026 | Configuration: F-UV-000001 | Scale: 1:12            | Page 1 of 1 |
|                         | Designer      |          | 3/23/2026 |                            |                        |             |

PROPRIETARY AND CONFIDENTIAL  
 THE INFORMATION CONTAINED IN THIS DRAWING IS THE SOLE PROPERTY OF WATERLOO BIOFILTER SYSTEMS. ANY REPRODUCTION IN PART OR AS WHOLE WITHOUT THE WRITTEN PERMISSION OF WATERLOO BIOFILTER SYSTEMS IS PROHIBITED



65 MASSEY ROAD, SUITE C, GUELPH ON N1H 7M6  
 EMAIL: INFO@WATERLOO-BIOFILTER.COM  
 TEL: 519-856-0757 FAX: 519-856-0759